

LAMPIRAN

Lampiran 1. Jadwal Kegiatan

No.	Nama Kegiatan	2023					2024		Keterangan
		Bulan Ke-					Bulan Ke-		
		8	9	10	11	12	1	2	
1.	Studi literatur.								UNUGHA
2.	Pengumpulan data referensi.								UNUGHA
3.	Penyusunan proposal.								UNUGHA
4.	Seminar proposal TA.								UNUGHA
5.	Revisi proposal TA.								UNUGHA
6.	Persiapan alat dan bahan serta penyusunan bab IV & bab V.								Laboratorium Proses Manufaktur UNUGHA
7.	Pengujian mesin melter plastik.								Laboratorium Proses Manufaktur UNUGHA
8.	Seminar hasil penelitian.								UNUGHA
9.	Revisi laporan tugas akhir.								UNUGHA

Lampiran 2. Gambar Teknik

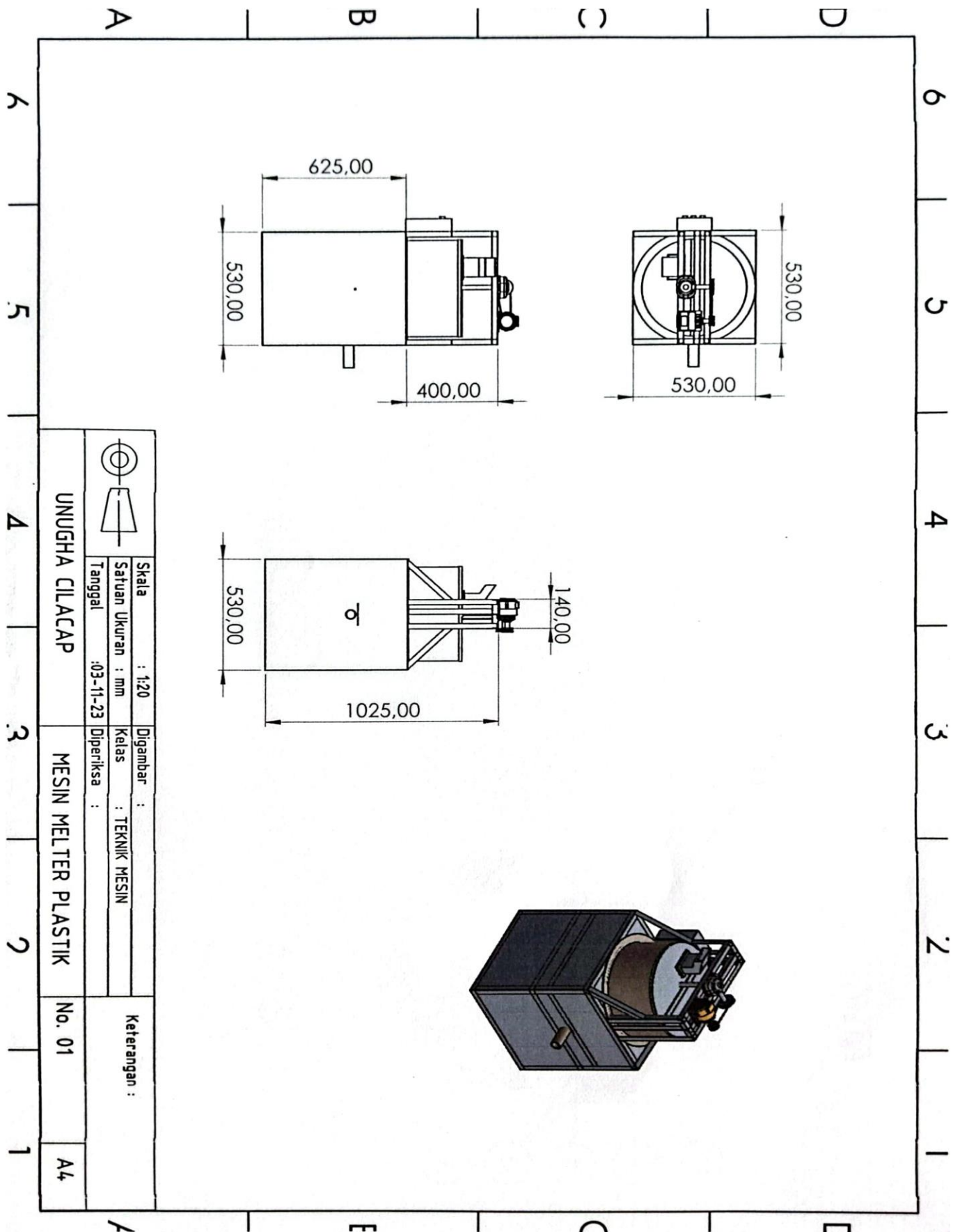

UNUGHA CILACAP		Skala : 1:20	Digambar :	Keterangan :
		Satuan Ukuran : mm	Kelas : TEKNIK MESIN	
MESIN MELTER PLASTIK		Tanggal : 03-11-23	Diperiksa :	No. 01
				A4

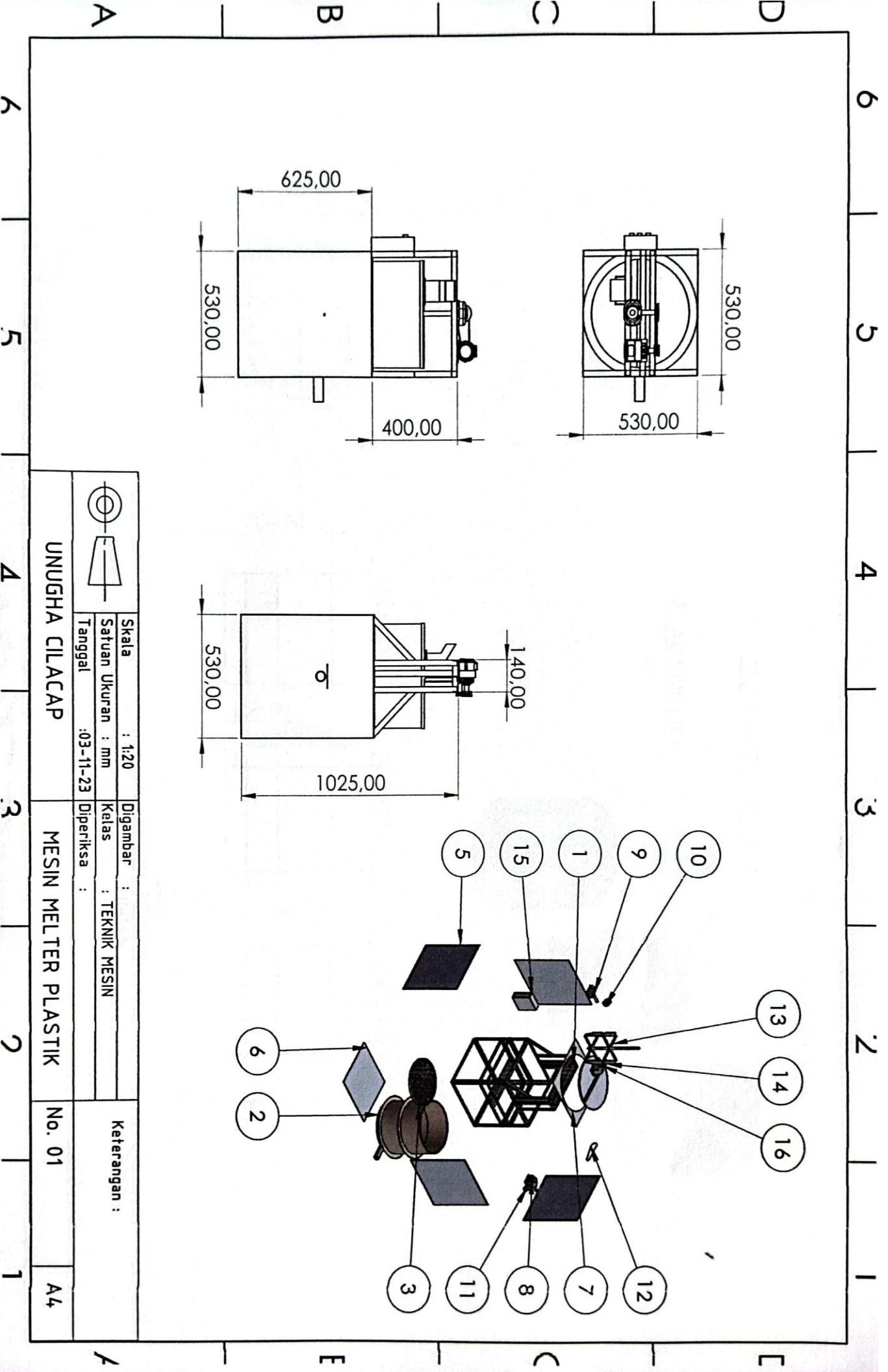

	Skala : 1:20	Digambar :	Keterangan :
	Satuan Ukuran : mm	Kelas : TEKNIK MESIN	
UNUGHA CILACAP		Tanggal : 03-11-23	Diperiksa :
MESIN MELTER PLASTIK		No. 01	A4

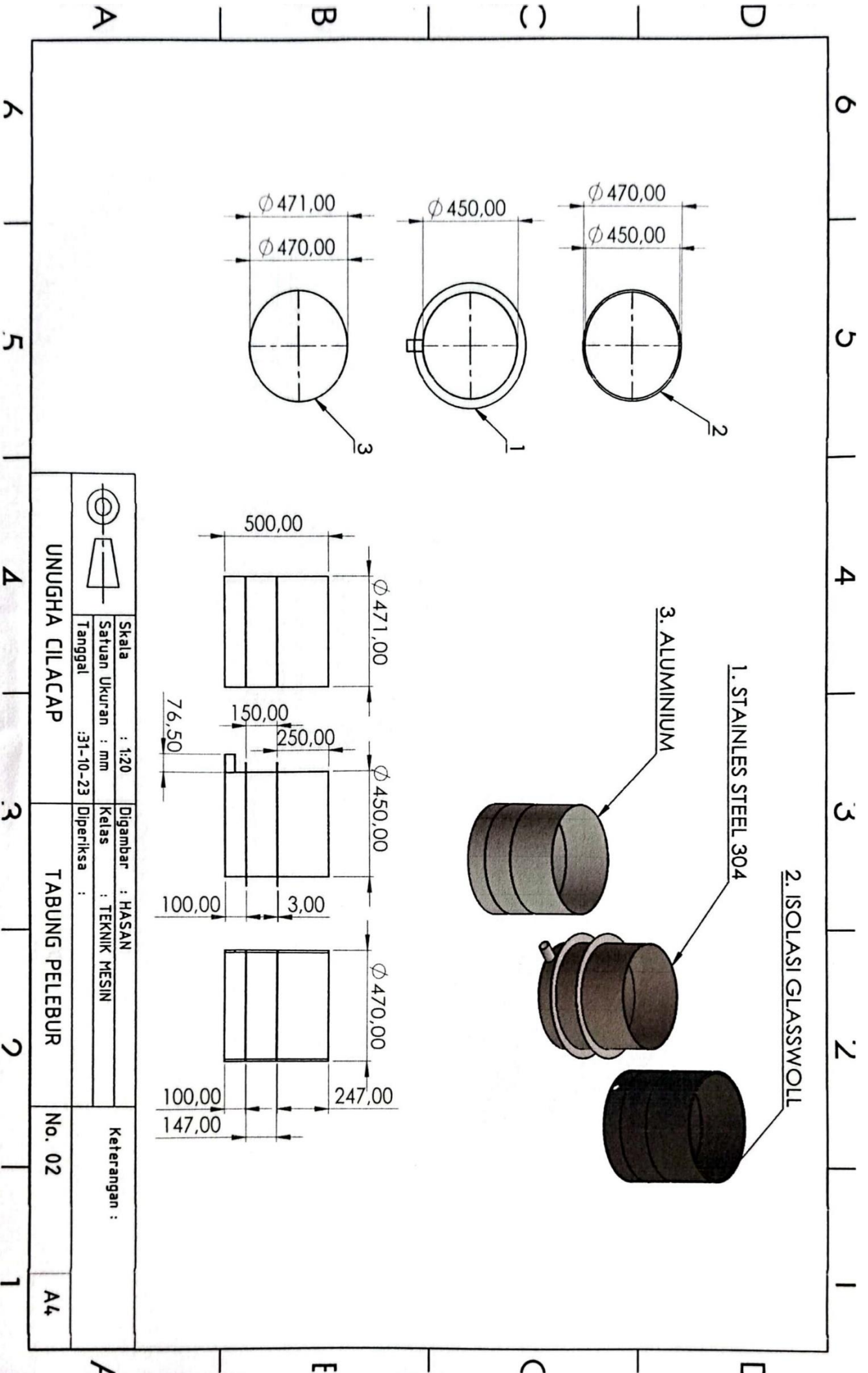

	Skala : 1:20	Digambar : HASAN	Keterangan :
	Satuan Ukuran : mm	Kelas : TEKNIK MESIN	
Tanggal : 31-10-23		Diperiksa :	
UNUGHA CILACAP		TABUNG PELEBUR	
No. 02		A4	

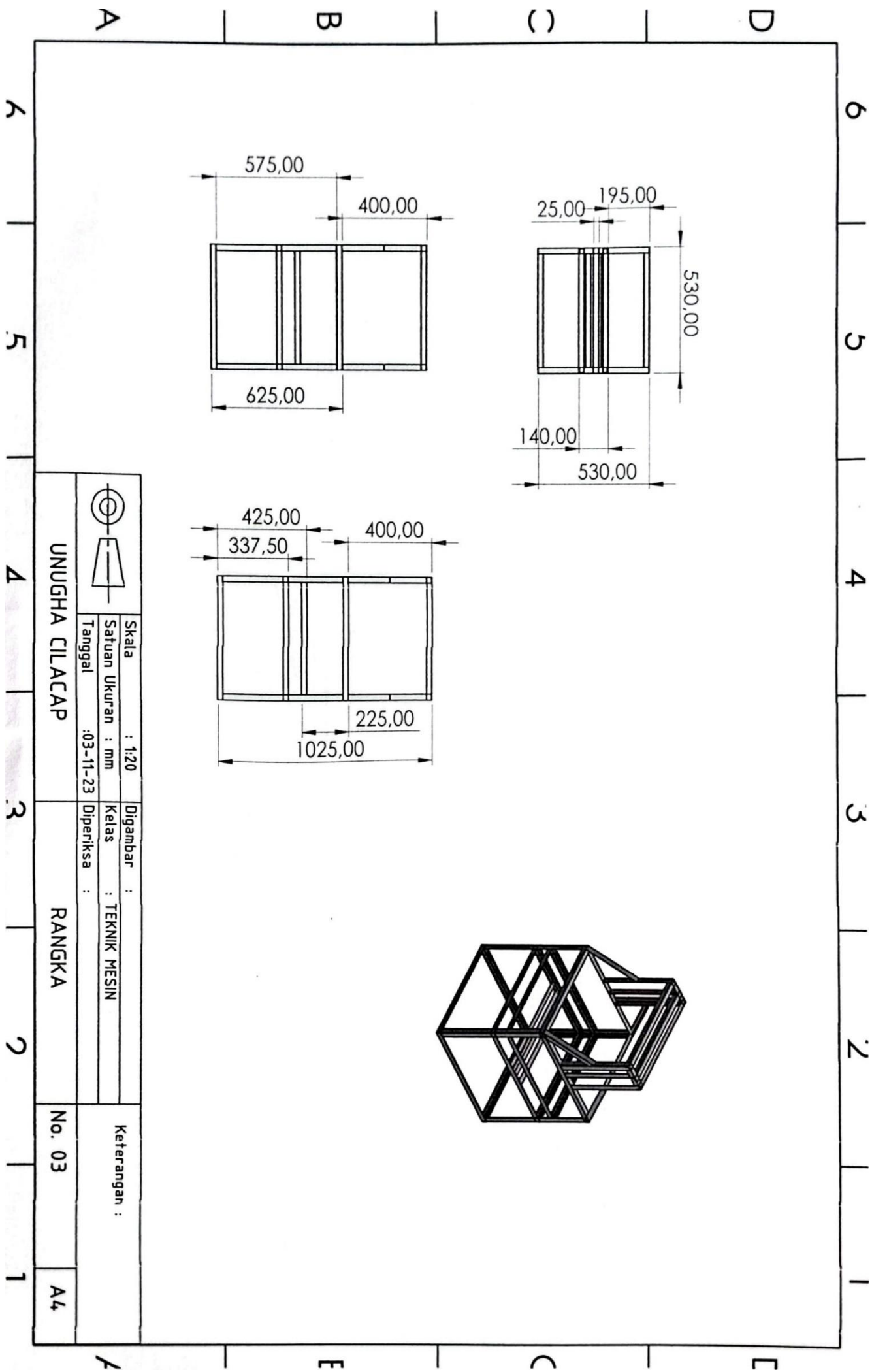

	Skala : 1:20	Digambar :	Keterangan :
	Satuan Ukuran : mm	Kelas : TEKNIK MESIN	
UNUGHA CILACAP	Tanggal : 03-11-23	Diperiksa :	No. 03
			A4

A B C D 1 2 3 4 5 6

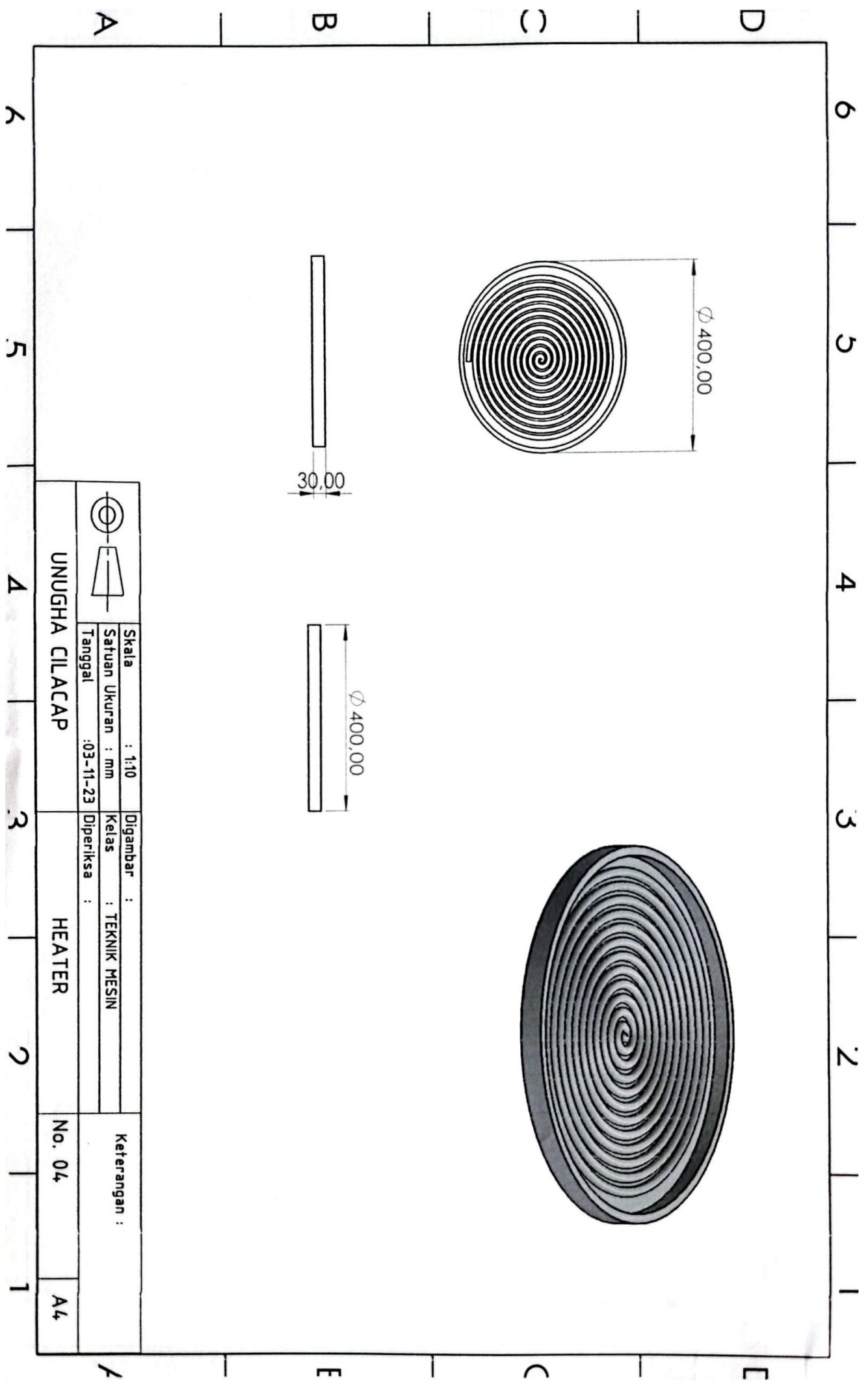

	Skala	: 1:10	Digambar	:	Keterangan :
	Satuan Ukuran	: mm	Kelas	:	
UNUGHA CILACAP		Tanggal	: 03-11-23	Diperiksa	:
		HEATER		No. 04	
					A4

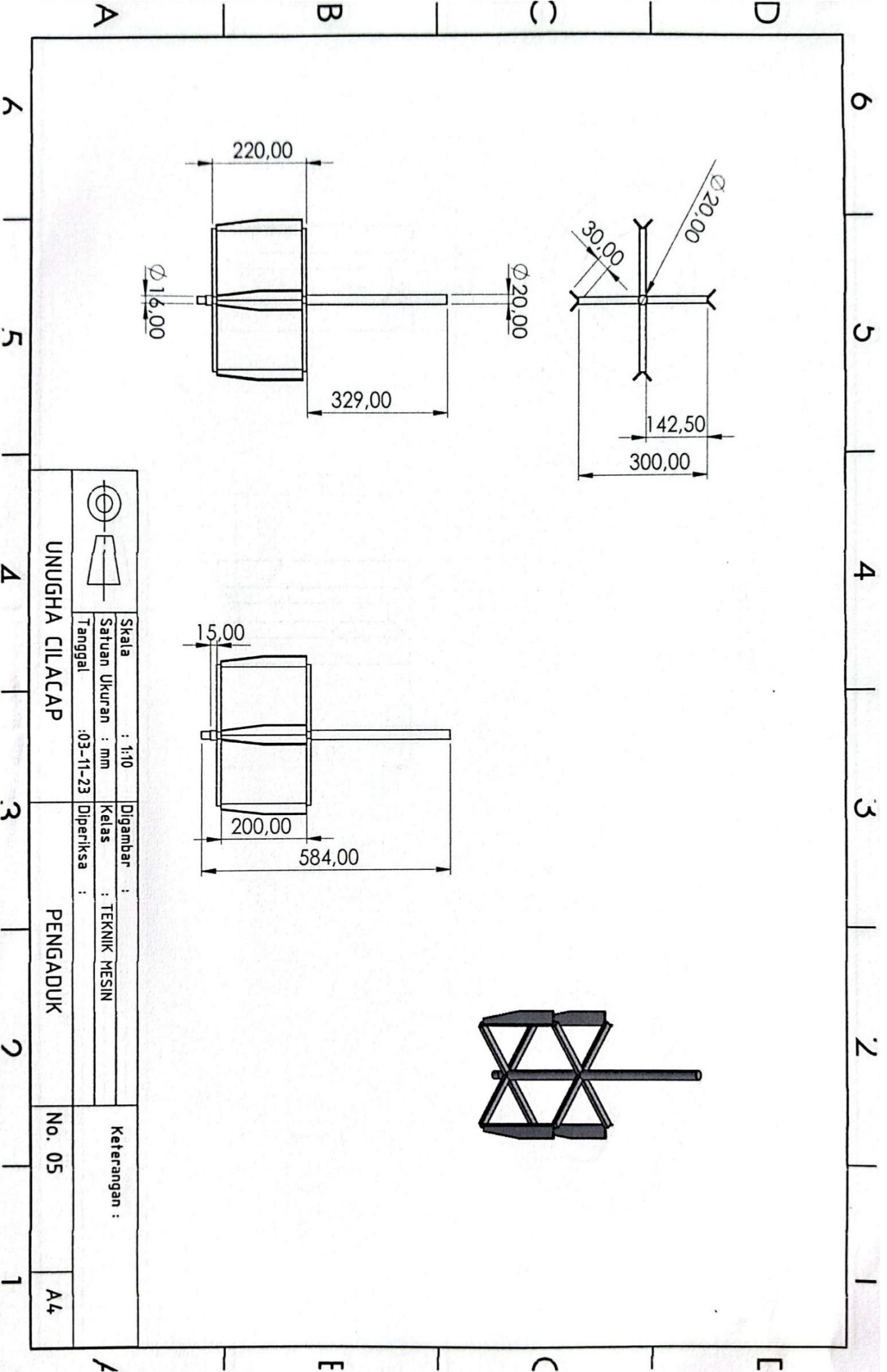

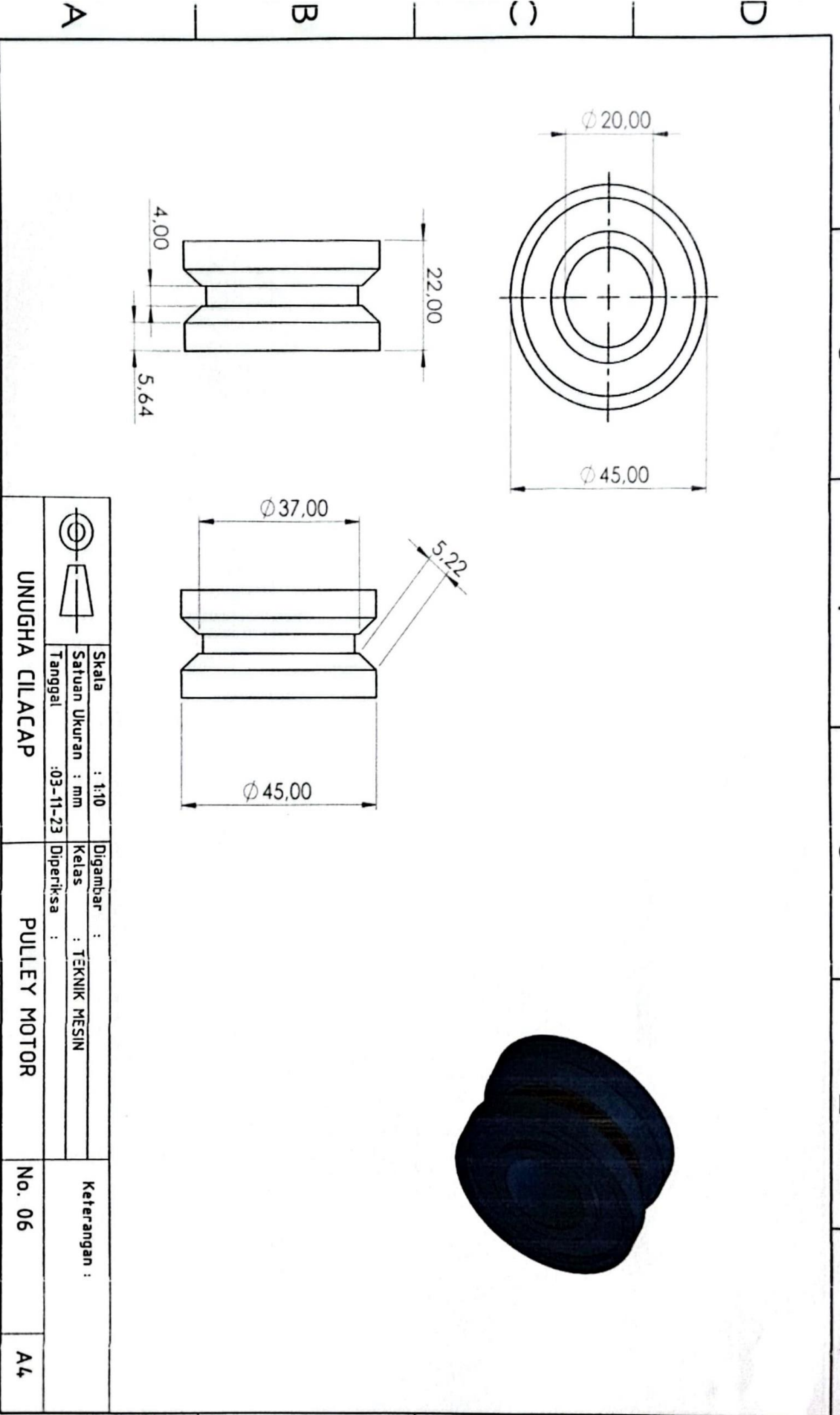

UNUGHA CILACAP	Skala : 1:10	Diganbar :	PULLEY MOTOR	Keterangan :
	Satuan Ukuran : mm	Kelas : TEKNIK MESIN		
	Tanggal : 03-11-23	Diperiksa :		
UNUGHA CILACAP			No. 06	A4

A B C D E 1 2 3 4 5 6

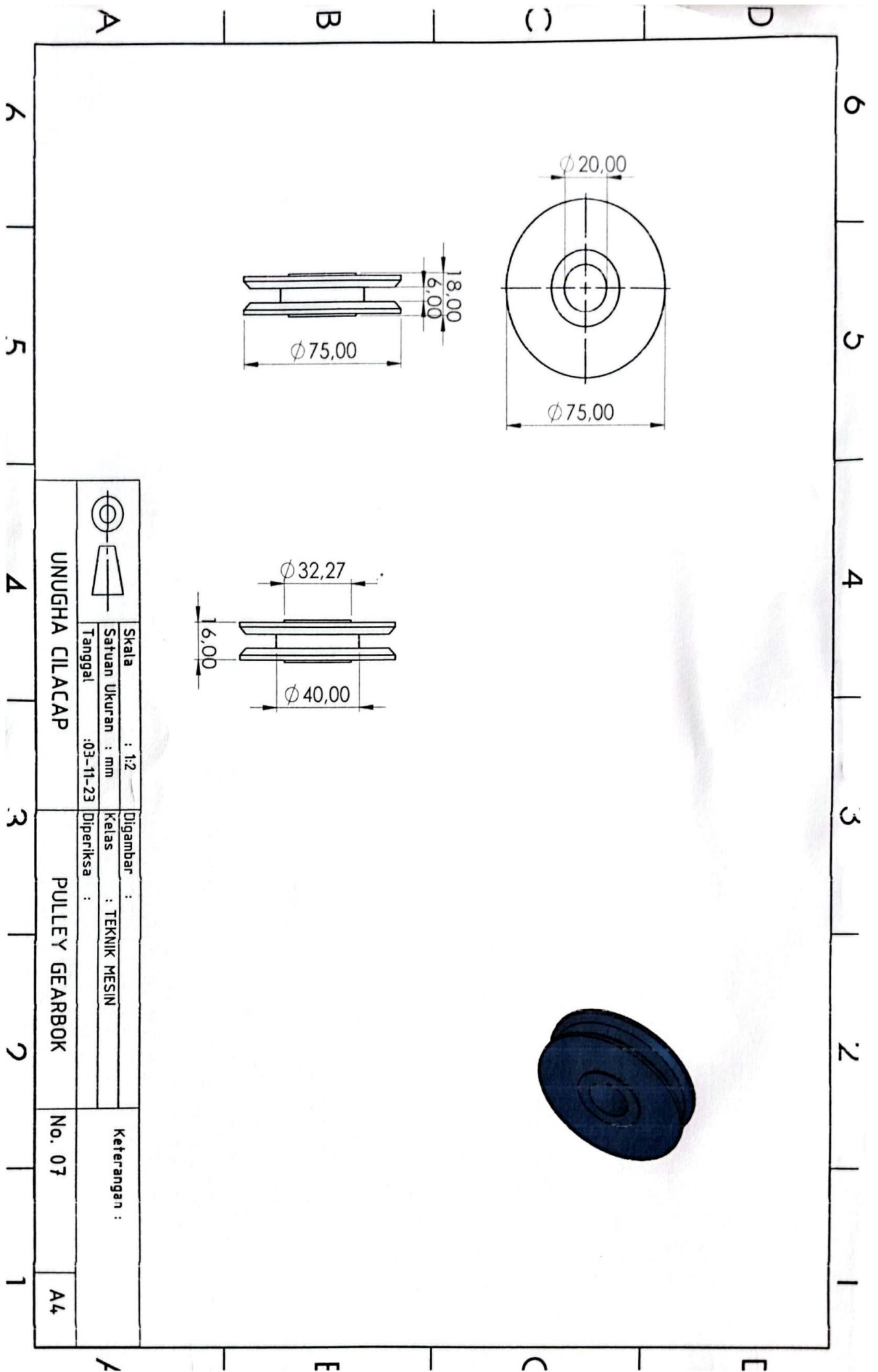

	Skala : 1:2	Digambar :	Keterangan :
	Satuan Ukuran : mm	Kelas : TEKNIK MESIN	
UNUGHA CILACAP		Diperiksa :	No. 07
PULLEY GEARBOX			A4
Tanggal : 03-11-23			

Lampiran 3. Pengujian Mesin



DATA RIWAYAT HIDUP



Nama : Rifa Nur Wahid
Tempat tanggal Lahir : Cilacap, 14 Januari 2000
Alamat : Jalan Sukun RT. 03 RW.03, Desa Kalisabuk
Kecamatan Kesugihan, Kabupaten Cilacap,
Provinsi Jawa Tengah.
Telepon : 0815 6610 607
Alamat Email : wahidrifa67@gmail.com

Riwayat Pendidikan :

- SDN 02 Kalisabuk Tahun 2006 – 2012
- SMPN 02 Slarang Tahun 2012 – 2015
- SMK Dr. Soetomo Tahun 2015 – 2018
- Universitas Nahdlatul Ulama Al-Ghazali Cilacap Tahun 2019 – 2024

Pengalaman Organisasi :

- Pengurus Himpunan Mahasiswa Teknik Mesin dengan jabatan sebagai Divisi Minat dan Bakat periode 2020 – 2021.