

LAMPIRAN

Lampiran 1. Jadwal Kegiatan

No.	Nama Kegiatan	Bulan ke-						Keterangan
		6	7	8	9	10	11	
1.	Studi Litelatur							UNUGHA
2.	Persiapan untuk proses pengeringan biji kopi							Laboratorium Konversi Energi dan perancangan mesin FTI UNUGHA
3.	Analisis Teknik							Laboratorium Konversi Energi dan perancangan mesin FTI UNUGHA
4	Seminar proposal							FTI UNUGHA
4.	Uji Kinerja ruang pengering							Laboratorium Konversi Energi dan perancangan mesin FTI UNUGHA
5.	Analisis data							Laboratorium Konversi Energi dan perancangan mesin FTI UNUGHA
6.	Seminar hasil penelitian							FTI UNUGHA
7.	Laporan Tugas Akhir							FTI UNUGHA

Lampiran 2. Disain Mesin Pengering Biji Kopi

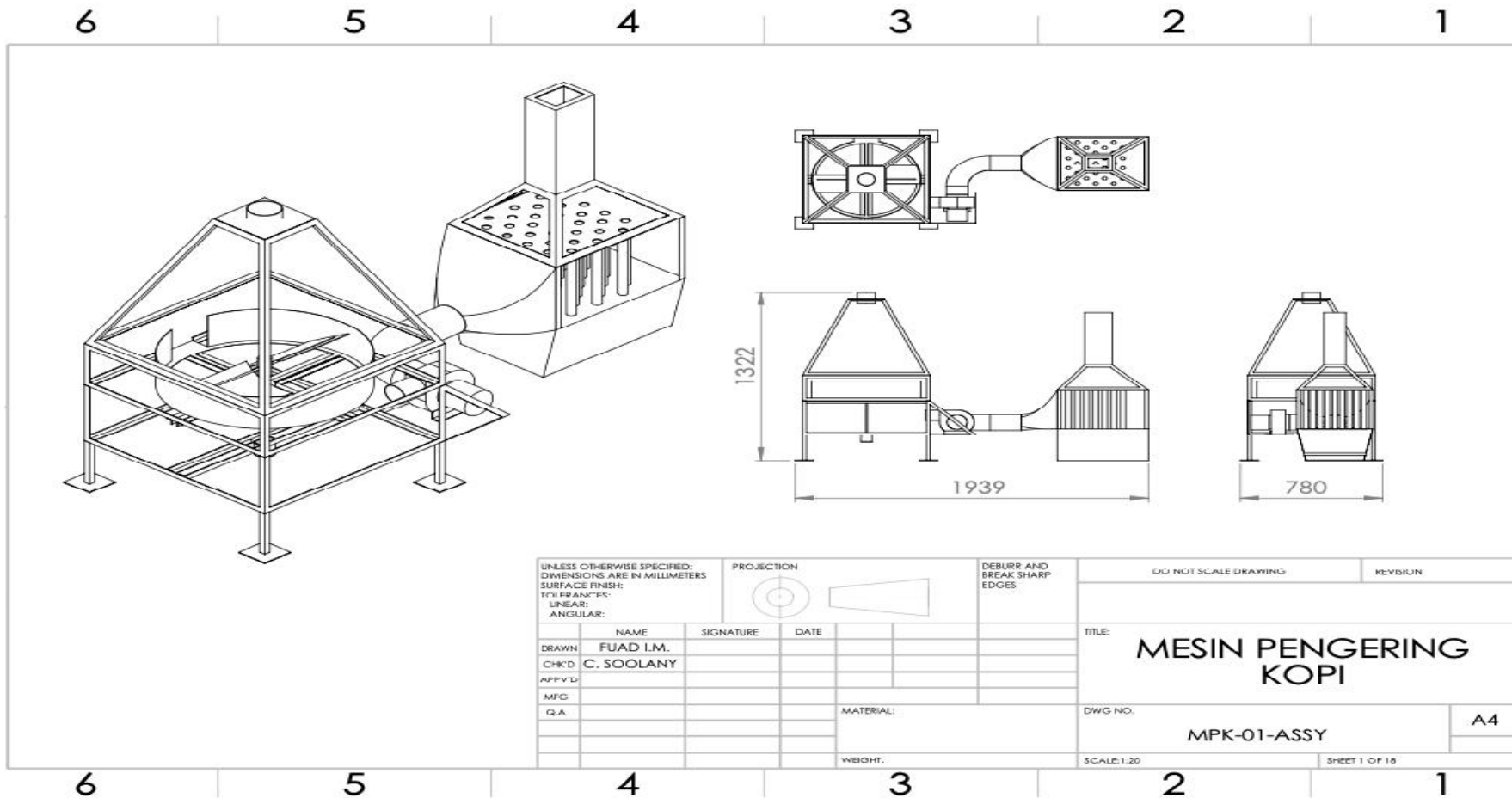

Lampiran 3. Ruang Pengering Biji Kopi

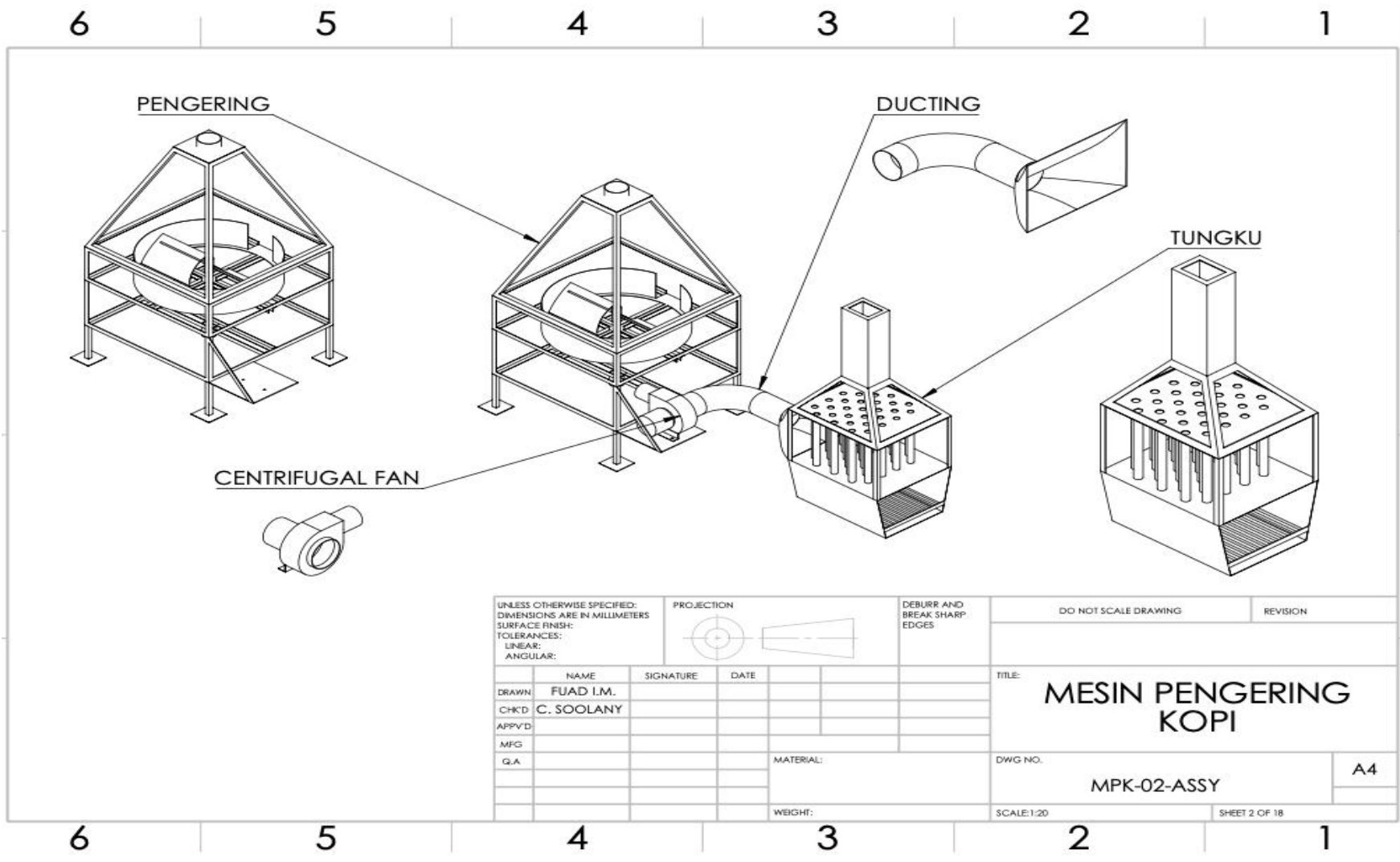

UNLESS OTHERWISE SPECIFIED: DIMENSIONS ARE IN MILLIMETERS SURFACE FINISH: TOLERANCES: LINEAR: ANGULAR:			PROJECTION 		DEBURR AND BREAK SHARP EDGES		DO NOT SCALE DRAWING		REVISION		
DRAWN:	NAME	SIGNATURE	DATE				TITLE: MESIN PENGERING KOPI				
CHK'D:	C. SOOLANY						DWG NO. MPK-02-ASSY				A4
APP'VD:							SCALE: 1:20				SHEET 2 OF 18
MFG:							MATERIAL:				
Q.A.							WEIGHT:				

Lampiran 4. Foto Kegiatan



Gambar Mesin Pengering Biji Kopi



Gambar Proses Menginstall Mesin Pengering Biji Kopi



Gambar Pengukuran Suhu



Gambar Pengukuran Suhu



Gambar Biji Kopi

6

5

4

3

2

1

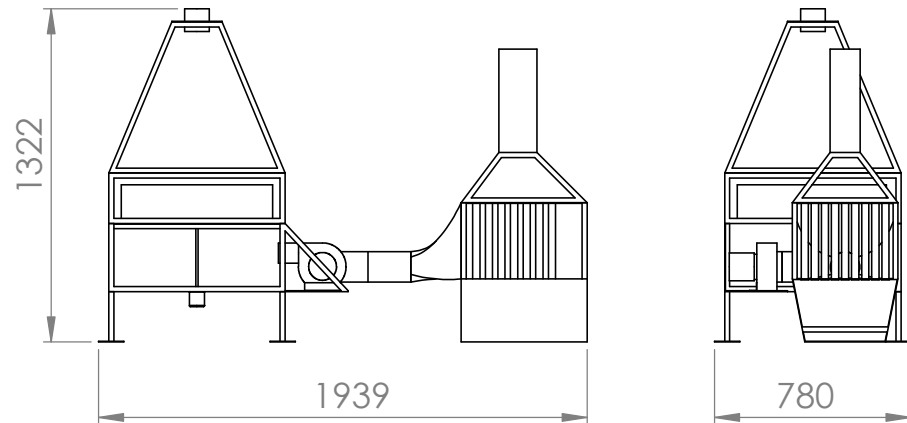
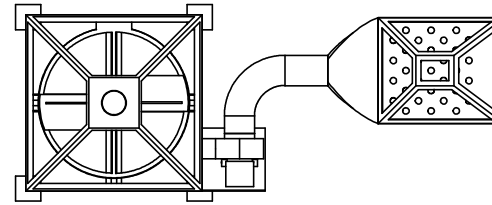
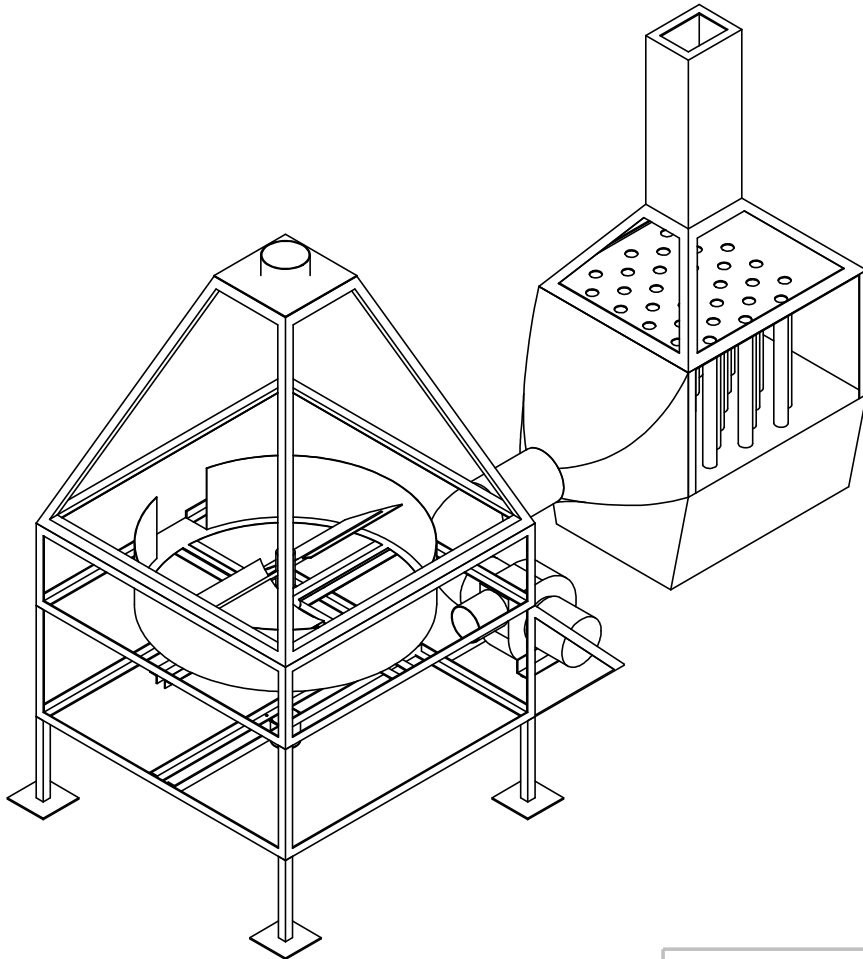

UNLESS OTHERWISE SPECIFIED:
 DIMENSIONS ARE IN MILLIMETERS
 SURFACE FINISH:
 TOLERANCES:
 LINEAR:
 ANGULAR:

PROJECTION

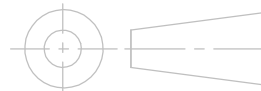

DEBURR AND
 BREAK SHARP
 EDGES

DO NOT SCALE DRAWING

REVISION

	NAME	SIGNATURE	DATE		
DRAWN	FUAD I.M.				
CHK'D	C. SOOLANY				
APPV'D					
MFG					
Q.A					
				MATERIAL:	
				WEIGHT:	

TITLE:

MESIN PENGERING
 KOPI

DWG NO.

MPK-01-ASSY

A4

SCALE: 1:20

SHEET 1 OF 18

6

5

4

3

2

1

6

5

4

3

2

1

PENGERING

DUCTING

TUNGKU

CENTRIFUGAL FAN

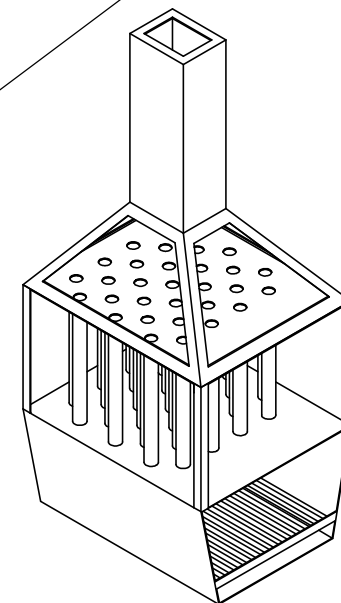
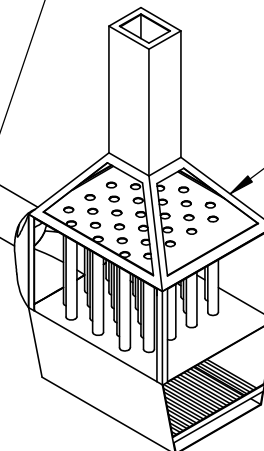
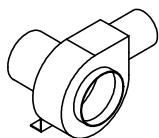
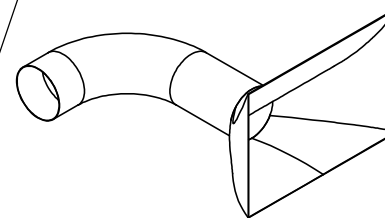
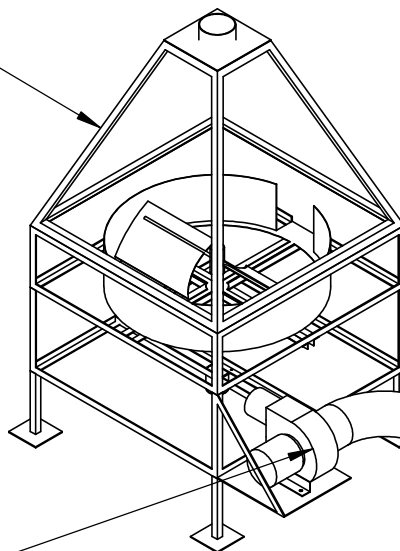
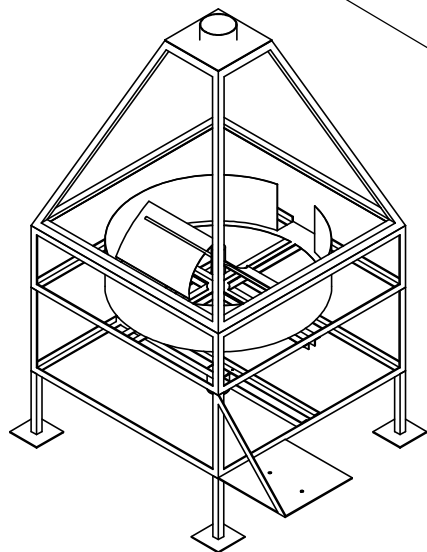

UNLESS OTHERWISE SPECIFIED:
 DIMENSIONS ARE IN MILLIMETERS
 SURFACE FINISH:
 TOLERANCES:
 LINEAR:
 ANGULAR:

PROJECTION

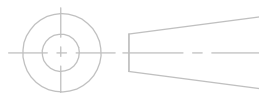

DEBURR AND
BREAK SHARP
EDGES

DO NOT SCALE DRAWING

REVISION

	NAME	SIGNATURE	DATE		
DRAWN	FUAD I.M.				
CHK'D	C. SOOLANY				
APPV'D					
MFG					
Q.A					
				MATERIAL:	
				WEIGHT:	

TITLE:

MESIN PENGERING
KOPI

DWG NO.

MPK-02-ASSY

A4

SCALE:1:20

SHEET 2 OF 18

6

5

4

3

2

1

6

5

4

3

2

1

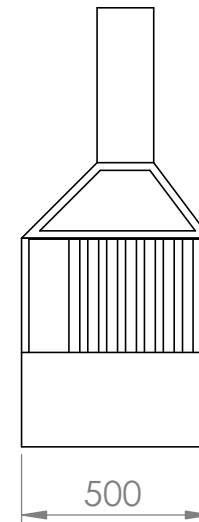
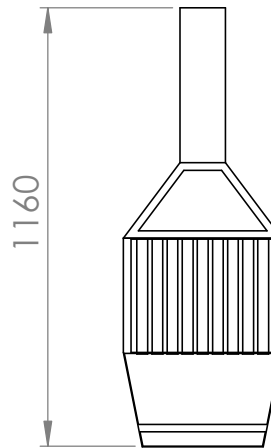
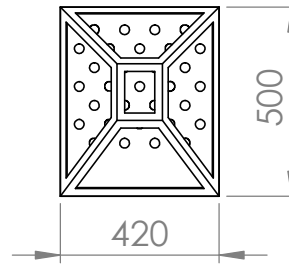
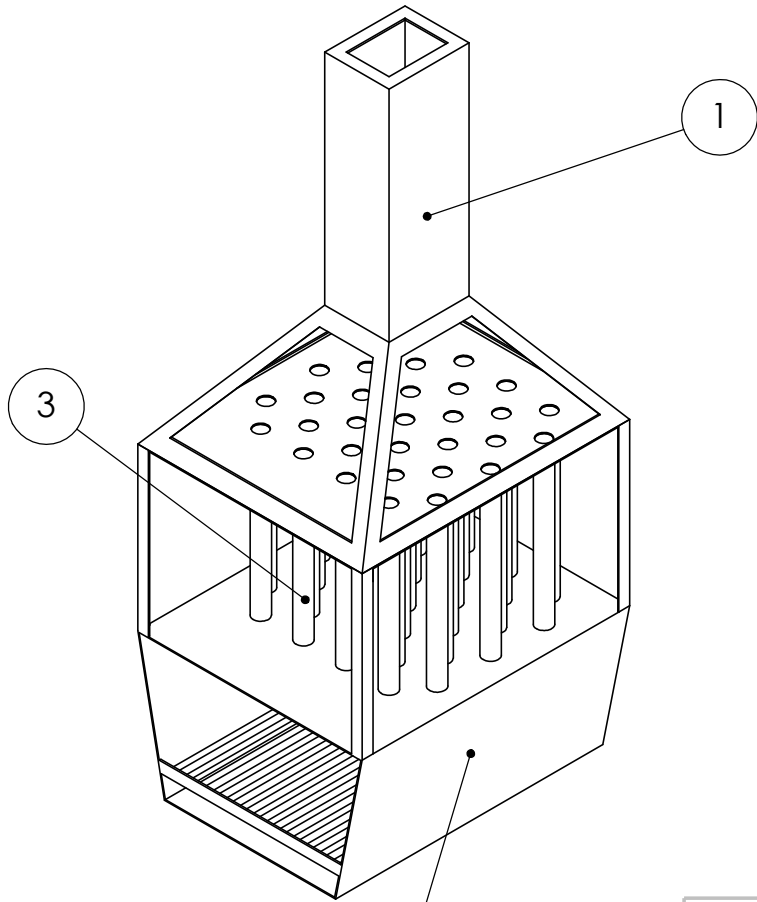

2

UNLESS OTHERWISE SPECIFIED:
DIMENSIONS ARE IN MILLIMETERS
SURFACE FINISH:
TOLERANCES:
LINEAR:
ANGULAR:

PROJECTION

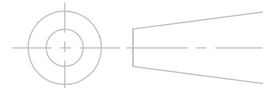

DEBURR AND
BREAK SHARP
EDGES

DO NOT SCALE DRAWING

REVISION

TUNGKU ASSY

	NAME	SIGNATURE	DATE		
DRAWN	FUAD I.M.				
CHK'D	C. SOOLANY				
APPV'D					
MFG					
Q.A				MATERIAL:	
				WEIGHT:	

TITLE:

MESIN PENGERING KOPI

DWG NO.

MPK-02-TUNGKU-00

A4

SCALE: 1:20

SHEET 3 OF 18

6

5

4

3

2

1

6

5

4

3

2

1

LUBANG UNTUK PIPA

FRONT

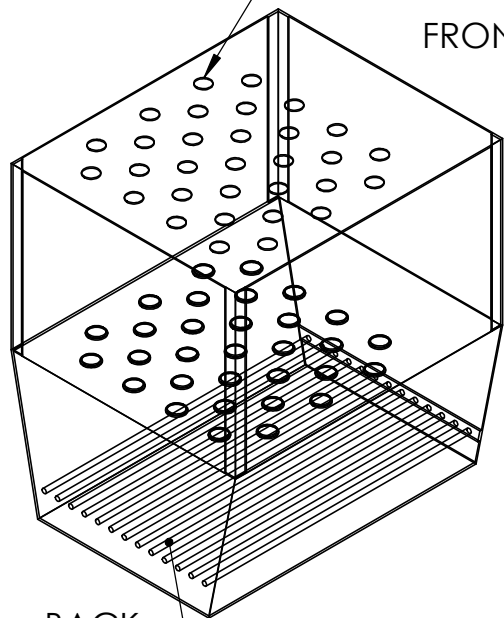

BACK

BAJA 8 MM

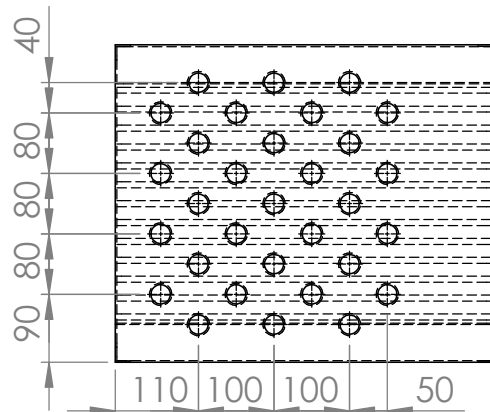

BAHAN PLAT BAJA 2 MM

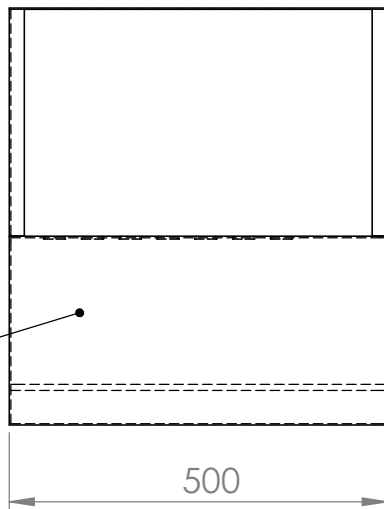

JARAK ANTAR BESI 25 MM

20

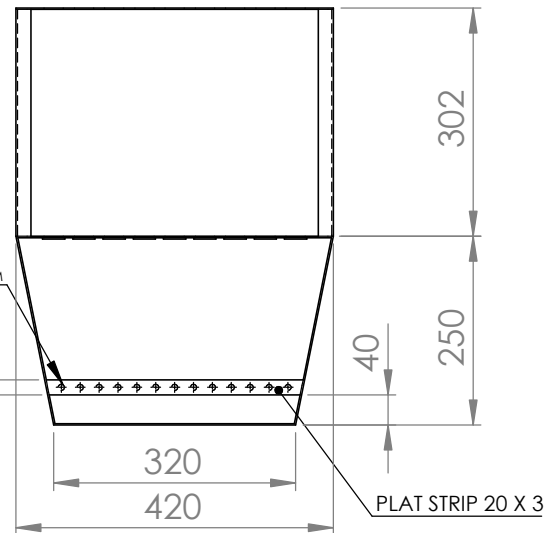

UNLESS OTHERWISE SPECIFIED:
 DIMENSIONS ARE IN MILLIMETERS
 SURFACE FINISH:
 TOLERANCES:
 LINEAR:
 ANGULAR:

PROJECTION

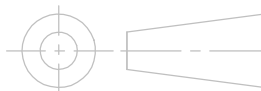

DEBURR AND
BREAK SHARP
EDGES

DO NOT SCALE DRAWING

REVISION

	NAME	SIGNATURE	DATE		
DRAWN	FUAD I.M.				
CHK'D	C. SOOLANY				
APPV'D					
MFG					
Q.A					
				MATERIAL:	
				WEIGHT:	

TITLE:

MESIN PENGERING KOPI

DWG NO.

MPK-02-TUNGKU-02

A4

SCALE:1:20

SHEET 4 OF 18

6

5

4

3

2

1

6

5

4

3

2

1

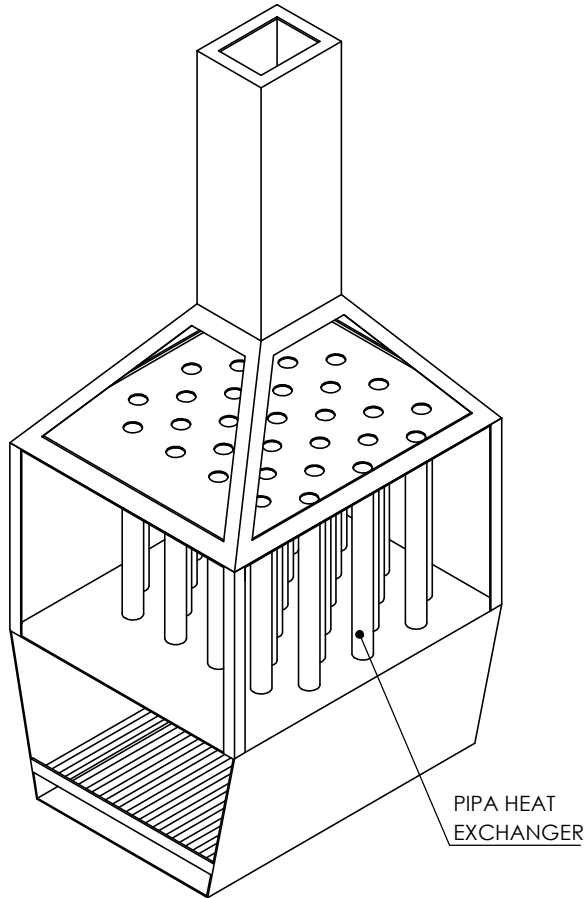

PIPA 1 INCH

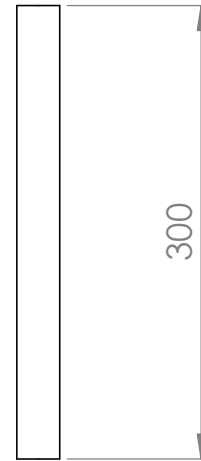

300

PIPA HEAT EXCHANGER

UNLESS OTHERWISE SPECIFIED: DIMENSIONS ARE IN MILLIMETERS SURFACE FINISH: TOLERANCES: LINEAR: ANGULAR:		PROJECTION 		DEBURR AND BREAK SHARP EDGES		DO NOT SCALE DRAWING		REVISION	
DRAWN FUAD I.M.		SIGNATURE		DATE		TITLE: MESIN PENGERING KOPI			
CHK'D C. SOOLANY									
APPV'D									
MFG									
Q.A									
				MATERIAL:		DWG NO. MPK-02-TUNGKU-03		A4	
				WEIGHT:		SCALE: 1:20		SHEET 5 OF 18	

6

5

4

3

2

1

6

5

4

3

2

1

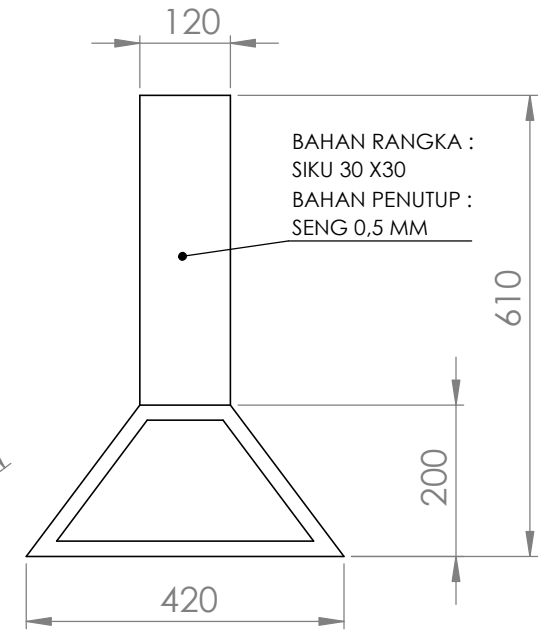
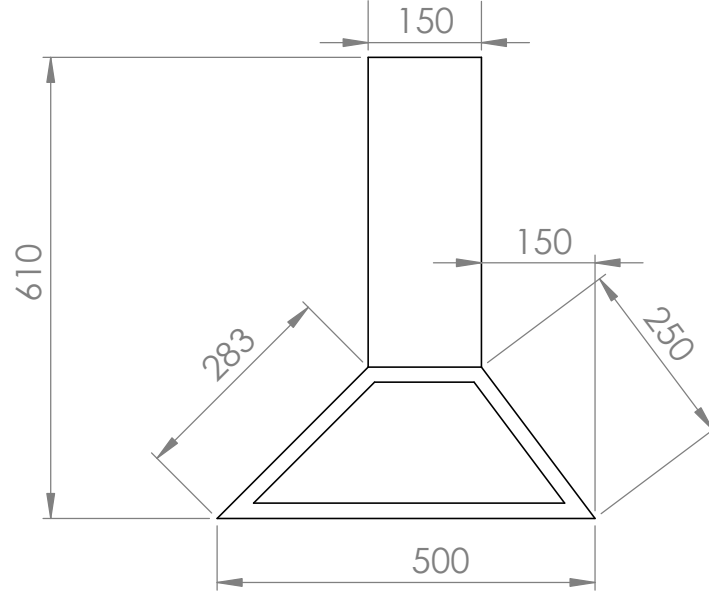
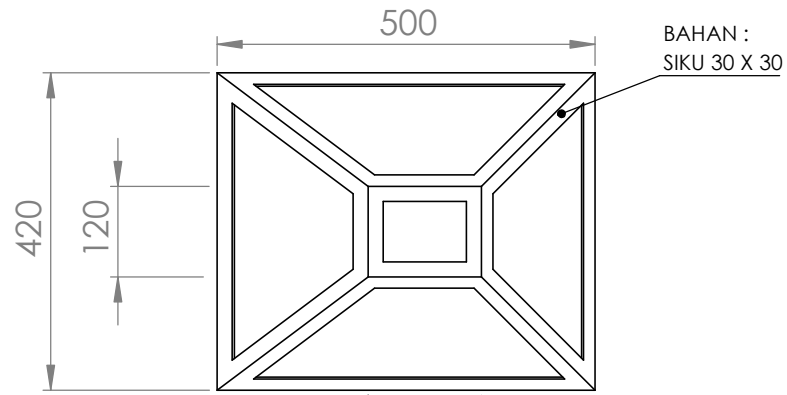
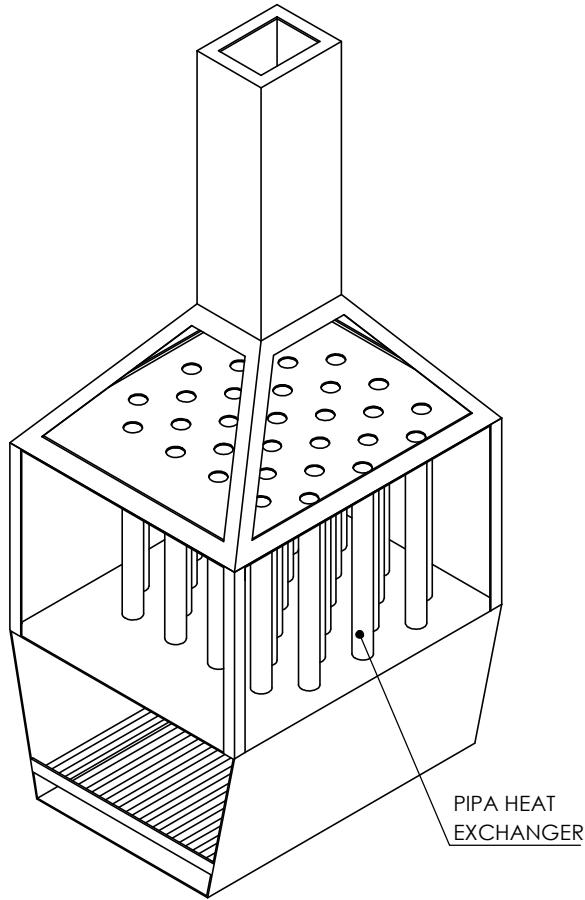

UNLESS OTHERWISE SPECIFIED:
DIMENSIONS ARE IN MILLIMETERS
SURFACE FINISH:
TOLERANCES:
LINEAR:
ANGULAR:

PROJECTION

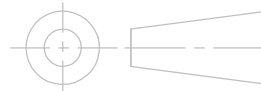

DEBURR AND
BREAK SHARP
EDGES

DO NOT SCALE DRAWING

REVISION

	NAME	SIGNATURE	DATE		
DRAWN	FUAD I.M.				
CHK'D	C. SOOLANY				
APPV'D					
MFG					
Q.A					
				MATERIAL:	
				WEIGHT:	

TITLE:
**MESIN PENGERING
KOPI**

DWG NO.
MPK-02-TUNGKU-01 A4

SCALE: 1:20 SHEET 6 OF 18

6

5

4

3

2

1

6

5

4

3

2

1

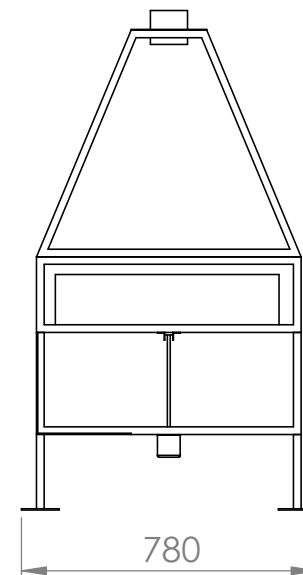
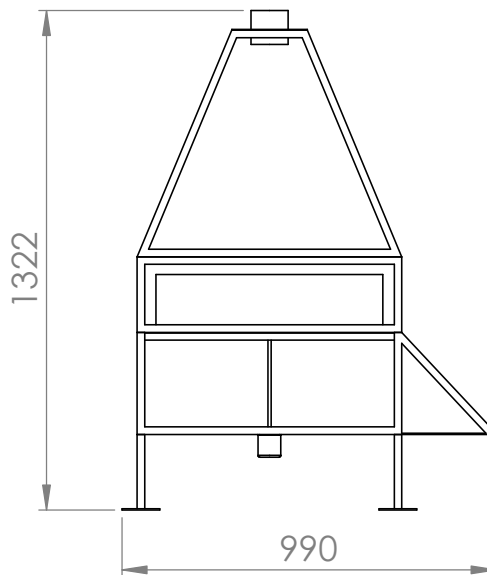
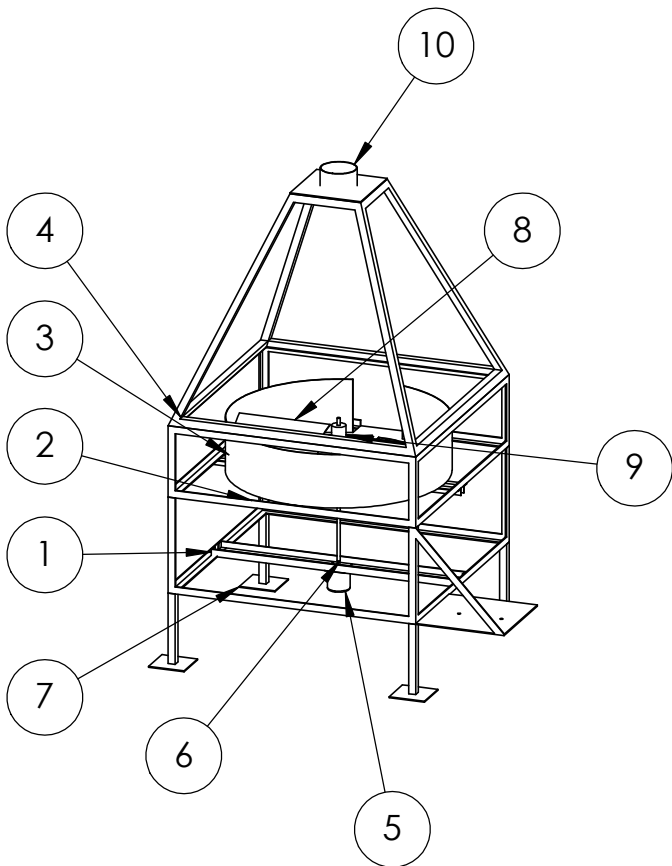
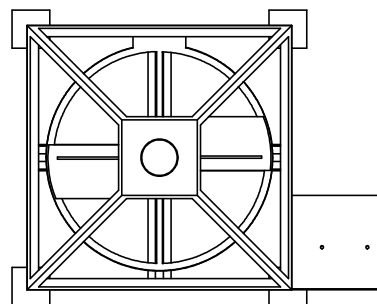

UNLESS OTHERWISE SPECIFIED:
 DIMENSIONS ARE IN MILLIMETERS
 SURFACE FINISH:
 TOLERANCES:
 LINEAR:
 ANGULAR:

PROJECTION

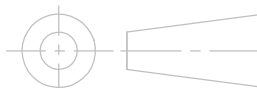

DEBURR AND
 BREAK SHARP
 EDGES

DO NOT SCALE DRAWING

REVISION

	NAME	SIGNATURE	DATE		
DRAWN	FUAD I.M.				
CHK'D	C. SOOLANY				
APPV'D					
MFG					
Q.A				MATERIAL:	
				WEIGHT:	

TITLE:

MESIN PENGERING
 KOPI

DWG NO.

MPK-03-PENGERING-00

A4

SCALE:1:20

SHEET 7 OF 18

6

5

4

3

2

1

6

5

4

3

2

1

BESI SIKU
30 X 30

BESI SIKU
30 X 30

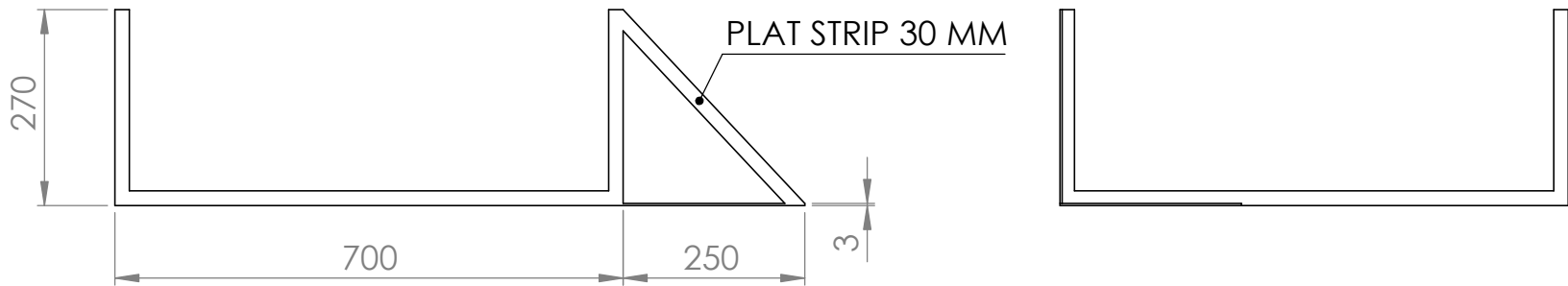
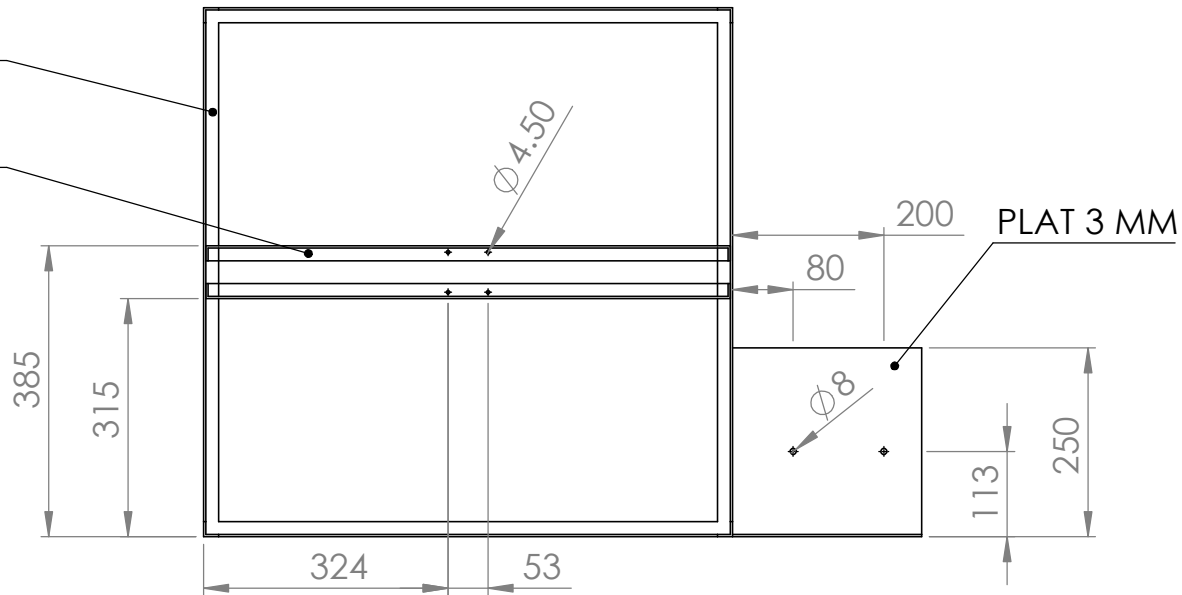

UNLESS OTHERWISE SPECIFIED:
DIMENSIONS ARE IN MILLIMETERS
SURFACE FINISH:
TOLERANCES:
LINEAR:
ANGULAR:

PROJECTION

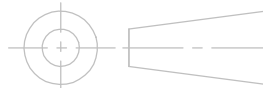

DEBURR AND
BREAK SHARP
EDGES

DO NOT SCALE DRAWING

REVISION

	NAME	SIGNATURE	DATE
DRAWN	FUAD I.M.		
CHK'D	C. SOOLANY		
APPV'D			
MFG			
Q.A			

TITLE:

MESIN PENGERING
KOPI

MATERIAL:

DWG NO.

MPK-03-PENGERING-01

A4

WEIGHT:

SCALE: 1:20

SHEET 8 OF 18

6

5

4

3

2

1

6

5

4

3

2

1

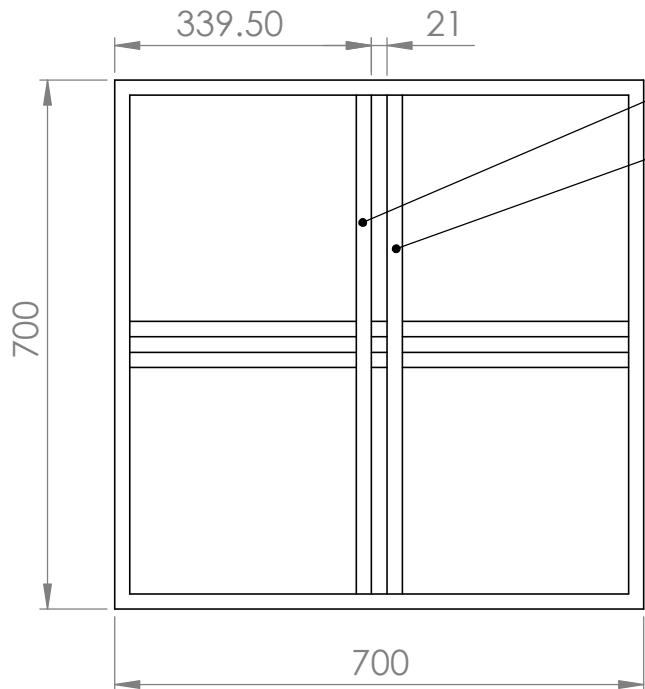

BESI STRIP 30 MM
 BESI STRIP 30 MM

BAHAN :
 SIKU 30 X 30
 (KEC DIJELASKAN DI GAMBAR)

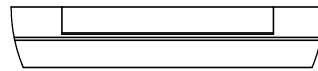
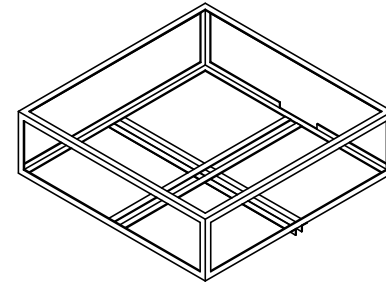

DETAIL A
 SCALE 1 : 5

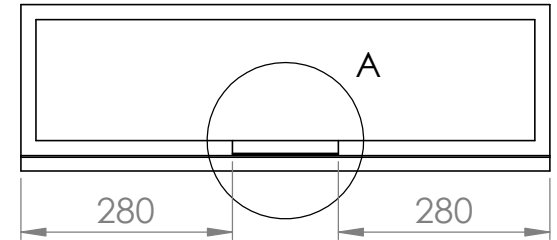
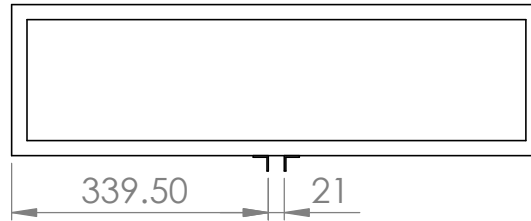
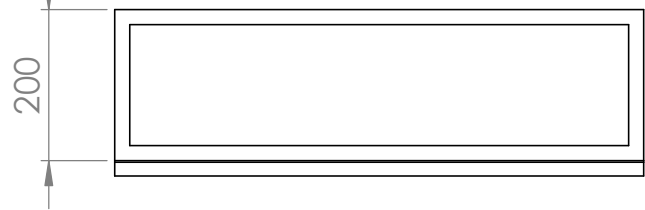

UNLESS OTHERWISE SPECIFIED:
 DIMENSIONS ARE IN MILLIMETERS
 SURFACE FINISH:
 TOLERANCES:
 LINEAR:
 ANGULAR:

PROJECTION

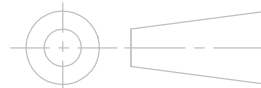

DEBURR AND
 BREAK SHARP
 EDGES

DO NOT SCALE DRAWING

REVISION

	NAME	SIGNATURE	DATE		
DRAWN	FUAD I.M.				
CHK'D	C. SOOLANY				
APPV'D					
MFG					
Q.A					
				MATERIAL:	
				WEIGHT:	

TITLE:

MESIN PENGERING
 KOPI

DWG NO.

MPK-02-PENGERING-02

A4

SCALE:1:20

SHEET 9 OF 18

6

5

4

3

2

1

6

5

4

3

2

1

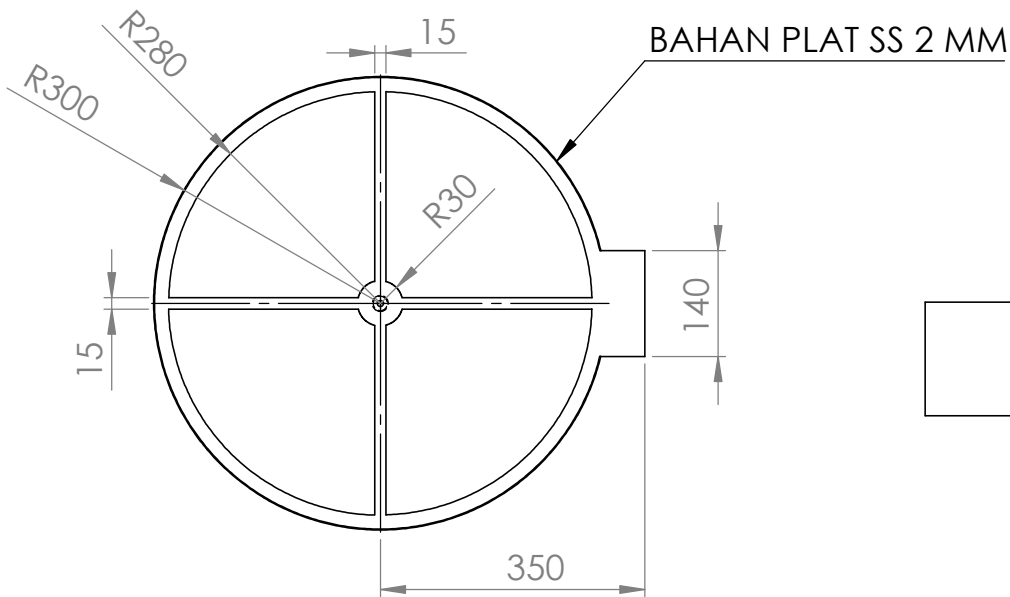

ALAS WIRE MESH 4 X 0.6

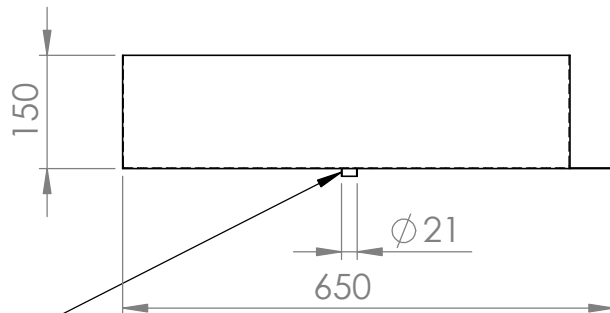
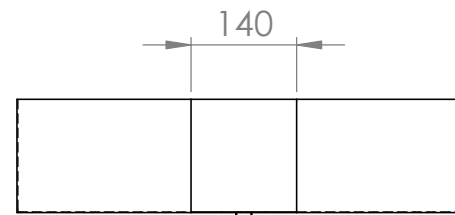
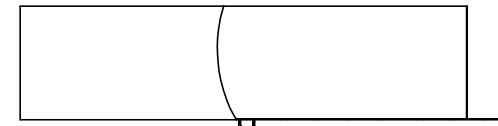
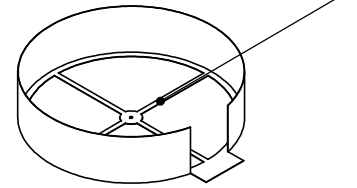

BEARING
TIPE 698

UNLESS OTHERWISE SPECIFIED:
DIMENSIONS ARE IN MILLIMETERS
SURFACE FINISH:
TOLERANCES:
LINEAR:
ANGULAR:

PROJECTION

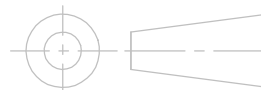

DEBURR AND
BREAK SHARP
EDGES

DO NOT SCALE DRAWING

REVISION

	NAME	SIGNATURE	DATE
DRAWN	FUAD I.M.		
CHK'D	C. SOOLANY		
APPV'D			
MFG			
Q.A			

MATERIAL:

WEIGHT:

TITLE:

MESIN PENGERING
KOPI

DWG NO.

MPK-02-PENGERING-03

A4

SCALE: 1:20

SHEET 10 OF 18

6

5

4

3

2

1

6

5

4

3

2

1

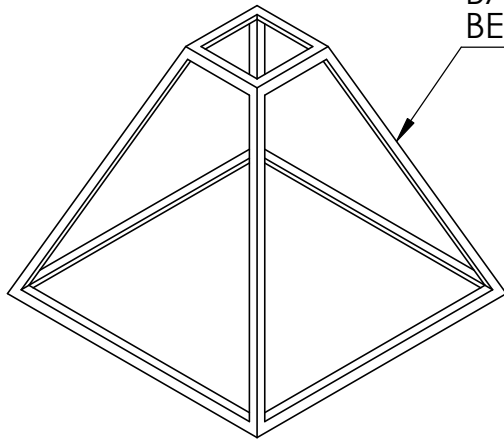

BAHAN :
BESI SIKU 30 X 30

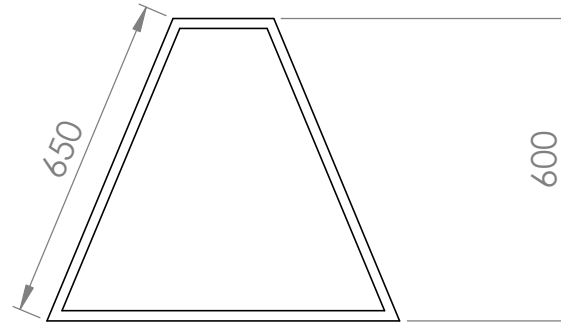
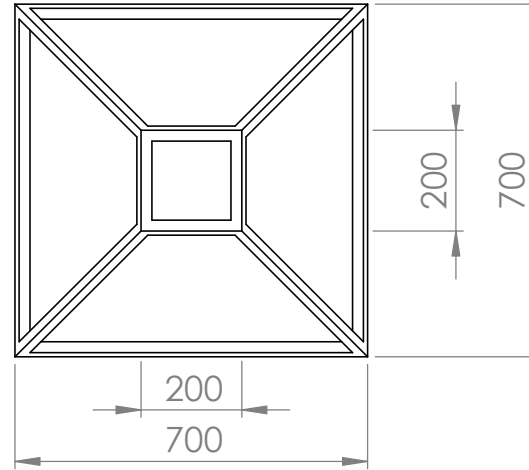

NOTE : KEEMPAT SISI DITUTUP
MENGUNAKAN SOLARTUFF 2 MM

UNLESS OTHERWISE SPECIFIED: DIMENSIONS ARE IN MILLIMETERS SURFACE FINISH: TOLERANCES: LINEAR: ANGULAR:			PROJECTION 		DEBURR AND BREAK SHARP EDGES		DO NOT SCALE DRAWING		REVISION		
DRAWN		NAME		SIGNATURE		DATE		TITLE:			
CHK'D		FUAD I.M.						MESIN PENGERING KOPI			
APP'VD		C. SOOLANY									
MFG								DWG NO.			
Q.A								MPK-02-PENGERING-04			
								A4			
								SCALE: 1:20			
								SHEET 11 OF 18			

6

5

4

3

2

1

6

5

4

3

2

1

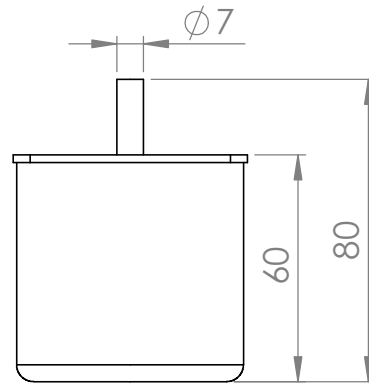
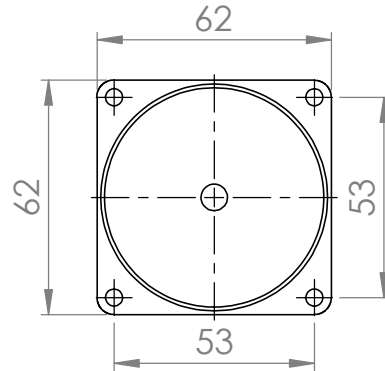
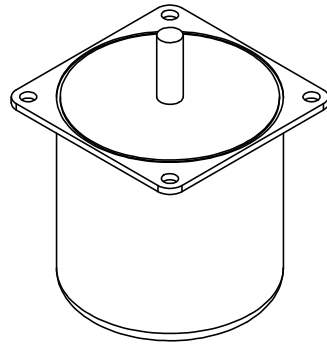

SPESIFIKASI :
 VOLT : AC220V
 DAYA : 4W
 RPM : 20RPM
 Low Speed Hi Torque Synchronous Motor

UNLESS OTHERWISE SPECIFIED: DIMENSIONS ARE IN MILLIMETERS SURFACE FINISH: TOLERANCES: LINEAR: ANGULAR:			PROJECTION 		DEBURR AND BREAK SHARP EDGES		DO NOT SCALE DRAWING		REVISION		
							TITLE: MESIN PENGERING KOPI				
							DWG NO. MPK-02-PENGERING-05		A4		
							SCALE: 1:20		SHEET 12 OF 18		

6

5

4

3

2

1

6

5

4

3

2

1



BAHAN :
POROS SS PEJAL 8 MM

UNLESS OTHERWISE SPECIFIED: DIMENSIONS ARE IN MILLIMETERS SURFACE FINISH: TOLERANCES: LINEAR: ANGULAR:		PROJECTION 		DEBURR AND BREAK SHARP EDGES		DO NOT SCALE DRAWING		REVISION	
	NAME	SIGNATURE	DATE			TITLE: MESIN PENGERING KOPI			
DRAWN	FUAD I.M.								
CHK'D	C. SOOLANY								
APPV'D									
MFG									
QA						DWG NO. MPK-02-PENGERING-06		A4	
					MATERIAL:				
					WEIGHT:	SCALE: 1:20		SHEET 13 OF 18	

6

5

4

3

2

1

6

5

4

3

2

1

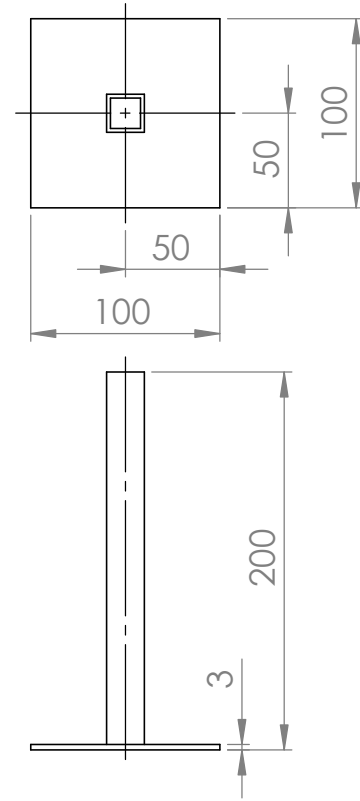
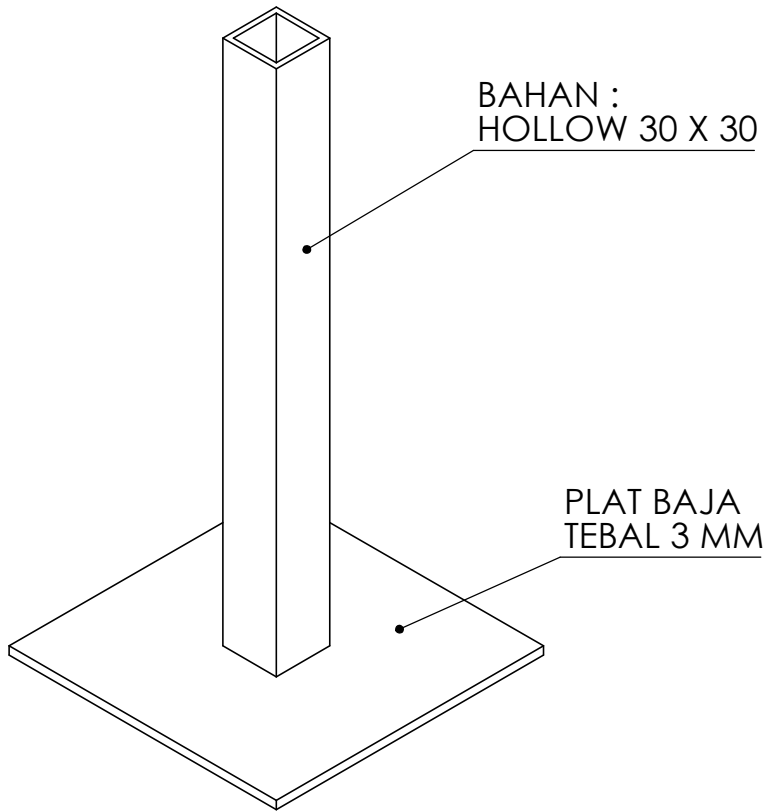

UNLESS OTHERWISE SPECIFIED:
 DIMENSIONS ARE IN MILLIMETERS
 SURFACE FINISH:
 TOLERANCES:
 LINEAR:
 ANGULAR:

PROJECTION

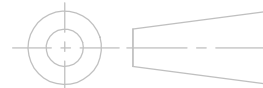

DEBURR AND
BREAK SHARP
EDGES

DO NOT SCALE DRAWING

REVISION

	NAME	SIGNATURE	DATE		
DRAWN	FUAD I.M.				
CHK'D	C. SOOLANY				
APPV'D					
MFG					
Q.A					
				MATERIAL:	
				WEIGHT:	

TITLE:

MESIN PENGERING KOPI

DWG NO.

MPK-02-PENGERING-07

A4

SCALE:1:20

SHEET 14 OF 18

6

5

4

3

2

1

6

5

4

3

2

1

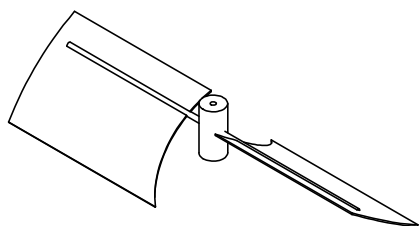
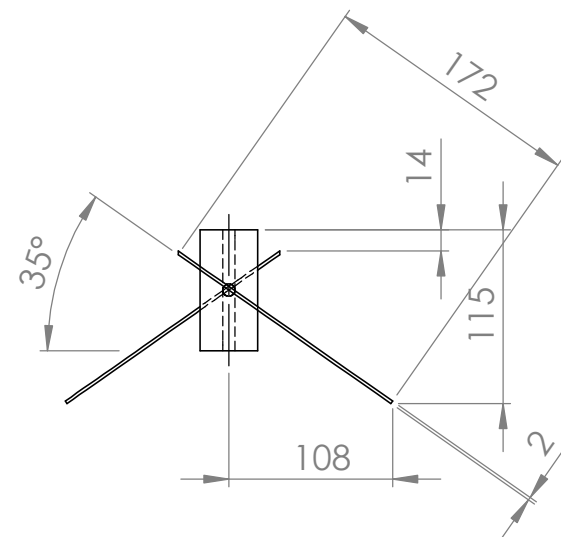
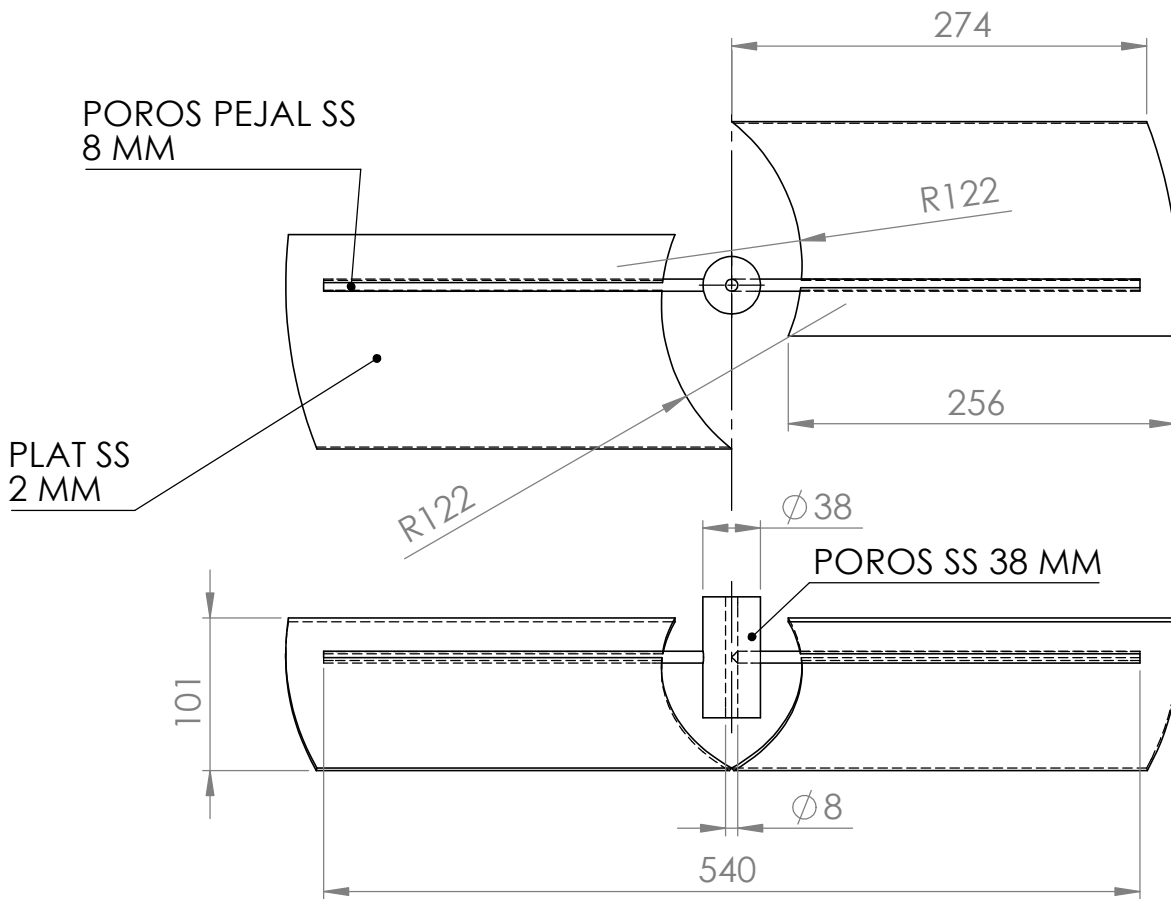

UNLESS OTHERWISE SPECIFIED:
 DIMENSIONS ARE IN MILLIMETERS
 SURFACE FINISH:
 TOLERANCES:
 LINEAR:
 ANGULAR:

PROJECTION

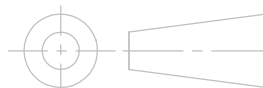

DEBURR AND
 BREAK SHARP
 EDGES

DO NOT SCALE DRAWING

REVISION

	NAME	SIGNATURE	DATE		
DRAWN	FUAD I.M.				
CHK'D	C. SOOLANY				
APPV'D					
MFG					
Q.A				MATERIAL:	
				WEIGHT:	

TITLE:

MESIN PENGERING
 KOPI

DWG NO.

MPK-02-PENGERING-08-09

A4

SCALE: 1:20

SHEET 15 OF 18

6

5

4

3

2

1

6

5

4

3

2

1

PLAT BESI
2 MM

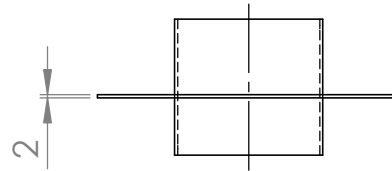
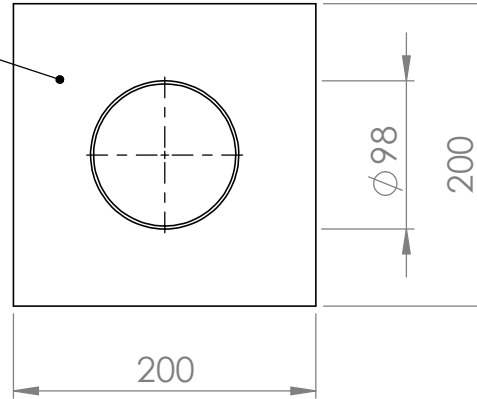

EXHAUST FAN
4 INCH

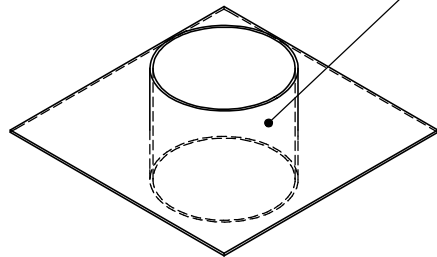

UNLESS OTHERWISE SPECIFIED: DIMENSIONS ARE IN MILLIMETERS SURFACE FINISH: TOLERANCES: LINEAR: ANGULAR:		PROJECTION 		DEBURR AND BREAK SHARP EDGES		DO NOT SCALE DRAWING		REVISION	
DRAWN	FUAD I.M.	SIGNATURE	DATE			TITLE: MESIN PENGERING KOPI			
CHK'D	C. SOOLANY								
APPV'D									
MFG									
Q.A									
				MATERIAL:		DWG NO.		A4	
				WEIGHT:		SCALE: 1:20		SHEET 16 OF 18	
						MPK-02-PENGERING-10			

6

5

4

3

2

1

6

5

4

3

2

1

SPESIFIKASI :
 KIPAS SENTRIFUGAL
 MERK : CKE
 TIPE : MC-DE M125R

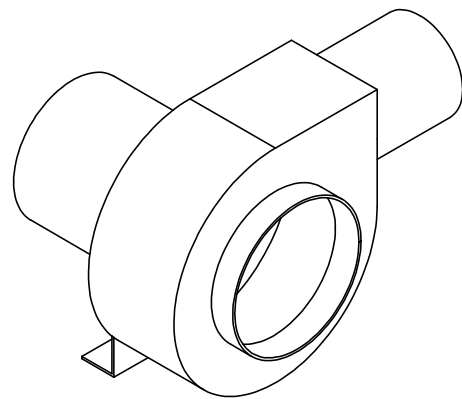
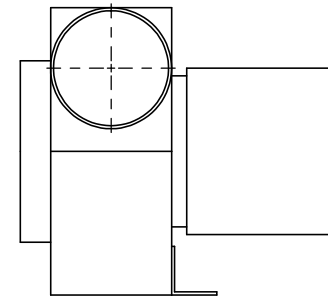
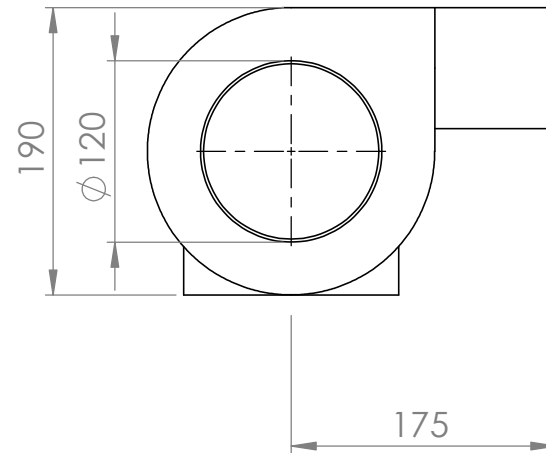
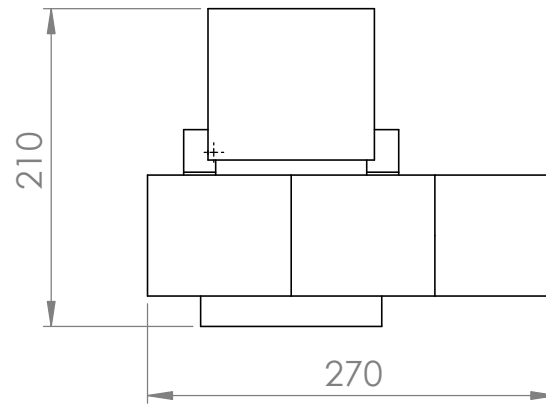

UNLESS OTHERWISE SPECIFIED:
 DIMENSIONS ARE IN MILLIMETERS
 SURFACE FINISH:
 TOLERANCES:
 LINEAR:
 ANGULAR:

PROJECTION

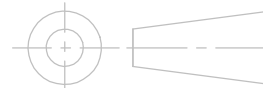

DEBURR AND
 BREAK SHARP
 EDGES

DO NOT SCALE DRAWING

REVISION

	NAME	SIGNATURE	DATE		
DRAWN	FUAD I.M.				
CHK'D	C. SOOLANY				
APPV'D					
MFG					
Q.A				MATERIAL:	
				WEIGHT:	

TITLE:

MESIN PENGERING
 KOPI

DWG NO.

MPK-03-CENTR FAN-00

A4

SCALE: 1:20

SHEET 17 OF 18

6

5

4

3

2

1

6

5

4

3

2

1

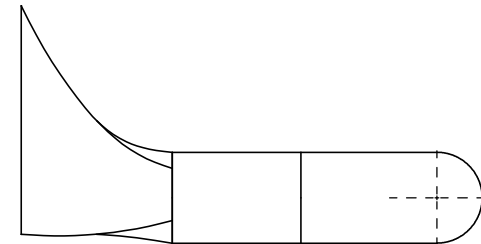
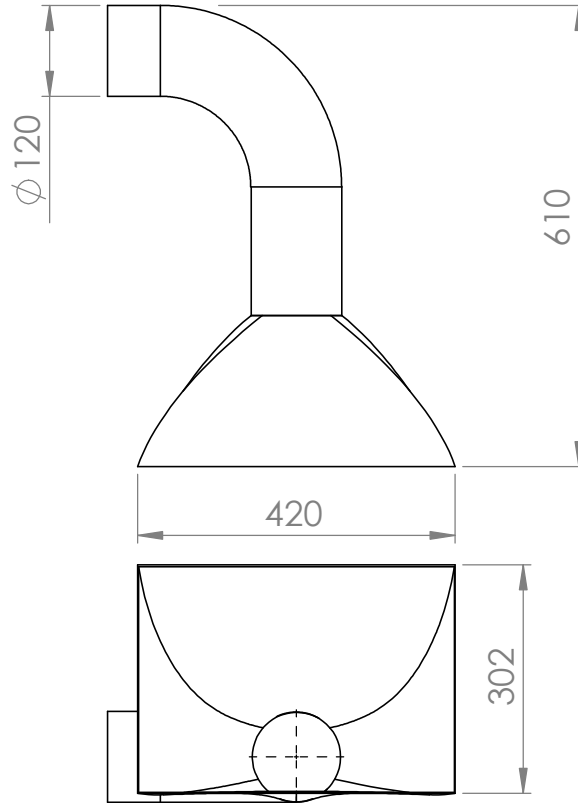
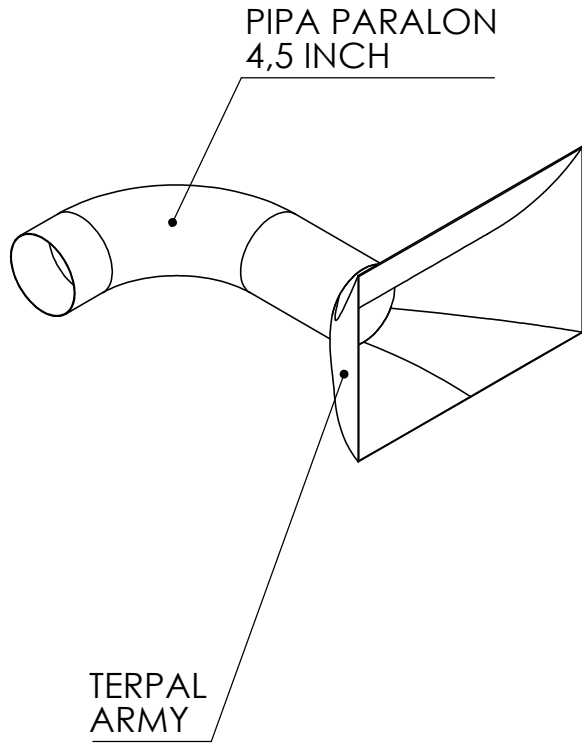

UNLESS OTHERWISE SPECIFIED:
 DIMENSIONS ARE IN MILLIMETERS
 SURFACE FINISH:
 TOLERANCES:
 LINEAR:
 ANGULAR:

PROJECTION

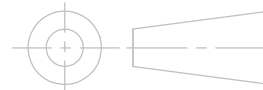

DEBURR AND
 BREAK SHARP
 EDGES

DO NOT SCALE DRAWING

REVISION

	NAME	SIGNATURE	DATE		
DRAWN	FUAD I.M.				
CHK'D	C. SOOLANY				
APPV'D					
MFG					
Q.A					
				MATERIAL:	
				WEIGHT:	

TITLE:

MESIN PENGERING
 KOPI

DWG NO.

MPK-03-CENTR FAN-00

A4

SCALE: 1:20

SHEET 18 OF 18

6

5

4

3

2

1