

LAMPIRAN

Lampiran 1. Jadwal Kegiatan Penelitian

No.	Nama Kegiatan	Bulan ke-						Keterangan
		12	1	2	3	4	5	
1.	Studi Litelatur							UNUGHA
2.	Persiapan Perancangan Mesin Pencetak Pelet							Laboratorium Konversi Energi dan perancangan mesin FTI UNUGHA
3.	Penyusunan Proposal Penelitian							Laboratorium Konversi Energi dan perancangan mesin FTI UNUGHA
4.	Seminar proposal							FTI UNUGHA
5.	Pencetakan Pelet dan Pengukuran getaran mekanis							Laboratorium Konversi Energi dan perancangan mesin.
6.	Analisis data							FTI UNUGHA
7.	Seminar hasil penelitian							UNUGHA
8.	Laporan Penelitian							UNUGHA

Lampiran 2. Disain Mesin Pencetak Pelet

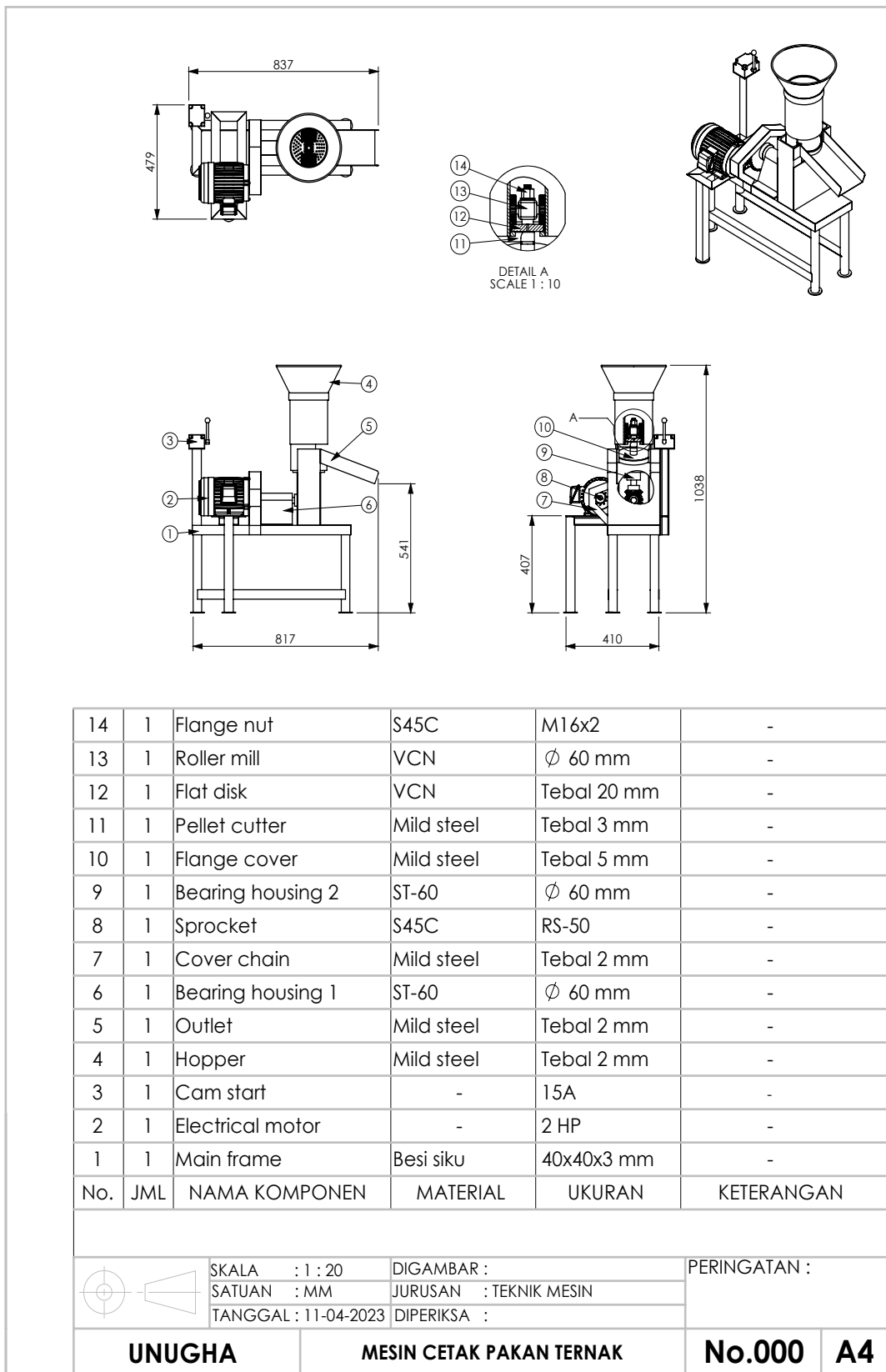

Lampiran 3. Dokumentasi Kegiatan





